

**YAMAHA**

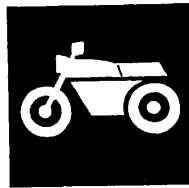

**PARTS  
CATALOGUE**

**DT125R'93 (3RN6)**

**ENGLAND**

/ 33RN-310E1

**YAMAHA**  
**GENUINE**  
Parts & Accessories

**A2**

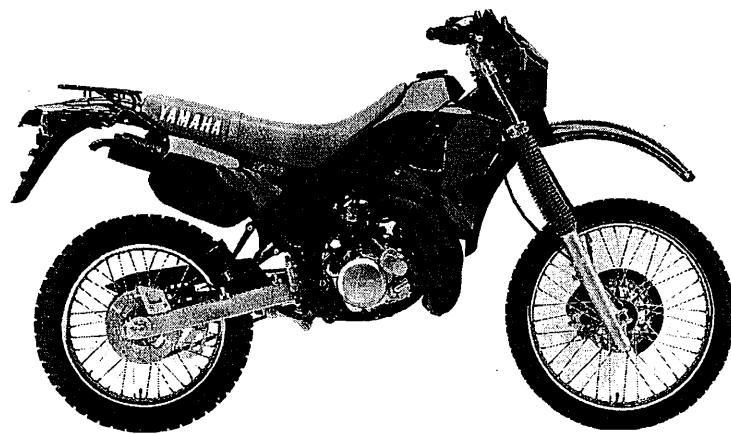

A3

# FOREWORD

This Parts Catalogue is related to the parts in use for the Yamaha DT125R'93(3RN6). When you are ordering replacement parts for the DT125R'93(3RN6), refer to this Parts Catalogue and quote both part numbers and part names correctly.

1. Modifications or additions which have been made after issue of the Parts Catalogue will be announced in the Yamaha Parts News.

It is advisable that according to the Yamaha Parts News you make necessary corrections to the Parts Catalogue on hand to keep it up-to-date.

2. Abbreviations

The following abbreviations are used in this Parts Catalogue.

- U.R. Use size (thickness) and/or number as required.
- U.N. Use as many as you need.
- A.P. Alternate Parts
- L.M. Local Made
- F# Frame No. (Applicable machine No.)

3. The parts marked with (\*) in the parts number column of this Catalogue are not supplied with by Yamaha, those have to be found locally.

4. Parts, which are to be supplied in the form of assemblies, are listed with an indentation of one letter's space, and a dot ( . ) is put against the name of each part.

**EXAMPLE** CARBURETOR ASS'Y  
                   . JET, pilot  
                   . NOZZLE, main

5. Indication of No. of constituent parts for assembly

The numeral appearing to the right of each constituent part under the description indicates the quantity of such parts for each individual assembly unit.

**EXAMPLE**

Part No.	Description	Q'ty	Remarks
2F5-83310-60	FRONT FLASHER LIGHT ASS'Y	2	
115-83311-60	. BULB (6V-18W)	1	
1M1-83309-60	. REFLECTOR	1	

6. Initial Serial No. and Color Code

(A) Frame Serial No.	3MD-036101 and following
(B) Engine Serial No.	3MD-036101 and following

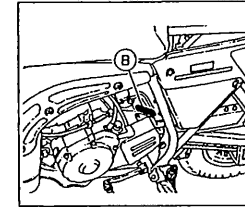
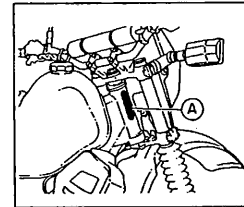

Color Code	Color Name	Abbreviate
0033	YAMAHA BLACK	YB
0206	PURPLISH WHITE SOLID 1	PWS1
00T7	PASTEL MINERAL BLUE	PMIB

7. Applicable colors of graphics are represented in the "Remarks" column by the letter(s) appropriately picked out of the full word(s) showing such colors.

**EXAMPLE**

Part No.	Description	Q'ty	Remarks
2N4-24110-00-X5	FUEL TANK COMP.	1	MAXIM RED
3J1-24240-10	. GRAPHIC, fuel tank set	1	for MXR

# CONTENTS

## ENGINE

Cylinder .....	B2
Crankshaft. Piston .....	B3~B4
Water Pump .....	B5
Radiator. Hose .....	B6~B7
Oil Pump .....	B8
Intake .....	B9~B10
Carburetor .....	B11~B12
Exhaust .....	B13
Crankcase .....	B14
Crankcase Cover 1 .....	B15
Starter .....	C2
Clutch .....	C3
Transmission .....	C4~C5
Tachometer Gear .....	C6
Shift Cam. Fork .....	C7
Shift Shaft .....	C8

## CHASSIS

Frame .....	C9
Fender .....	C10
Side Cover .....	C11~C13
Oil Tank .....	C14
Rear Arm .....	C15~D2
Rear Suspension .....	D3
Steering .....	D4
Front Fork .....	D5~D6
Fuel Tank .....	D7
Seat .....	D8
Front Wheel .....	D9

Front Brake Caliper .....	D10
Rear Wheel .....	D11
Rear Brake Caliper .....	D12
Steering Handle. Cable .....	D13
Front Master Cylinder .....	D14
Stand. Footrest .....	D15~E2
Rear Master Cylinder .....	E3
Cowling 1 .....	E4
Generator .....	E5
Flasher Light .....	E6~E7
Meter .....	E8
Headlight .....	E9
Taillight .....	E10
Handle Switch. Lever .....	E11
Electrical 1 .....	E12
Electrical 2 .....	E13

## INDEX

Numerical Index .....	M1~M4
-----------------------	-------

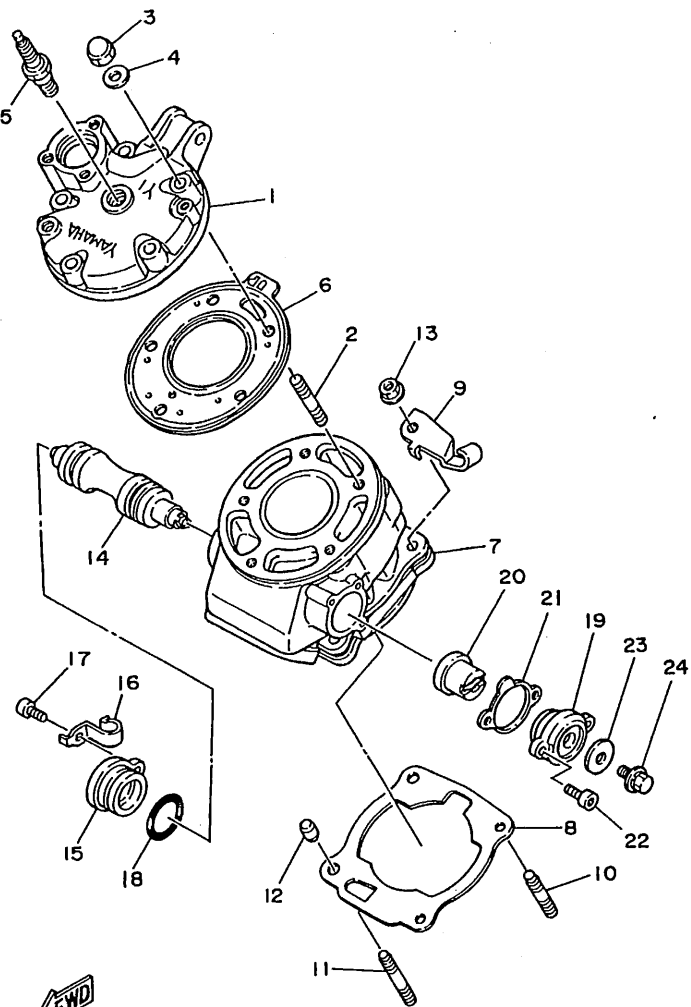

3MD1310-9010

FIG. 1 CYLINDER

REF. NO.	PART NO.	DESCRIPTION	Q'TY	REMARKS
1	3BN-11111-02	HEAD, cylinder 1	1	
2	90116-08394	BOLT, stud	5	
3	90176-08040	NUT, crown	5	
4	90201-08649	WASHER, plate	5	
5	94701-00188	PLUG, spark (NGK BR9ES)	1	
6	3MB-11181-00	GASKET, cylinder head 1	1	
7	3MB-11311-00	CYLINDER 1	1	
8	3BN-11351-10	GASKET, cylinder	1	
9	3BN-15441-00	HOLDER, clutch cable	1	
10	90116-08318	BOLT, stud	2	
11	90116-08388	BOLT, stud	2	
12	99510-10114	PIN, dowel	2	
13	90179-08491	NUT	4	
14	3MB-1131A-00	VALVE 1	1	
15	3BN-1131E-00	HOLDER 1	1	
16	90462-08174	CLAMP	1	
17	91316-05012	BOLT	1	
18	93210-30640	O-RING	1	
19	3DB-1131U-10	HOLDER 3	1	
20	3MD-1131F-00	HOLDER 2	1	
21	3RN-1131N-00	GASKET, holder	1	
22	91316-05016	BOLT	2	
23	90201-060A3	WASHER, plate	1	
24	90119-06061	BOLT, with washer	1	

FIG. 2 CRANKSHAFT. PISTON

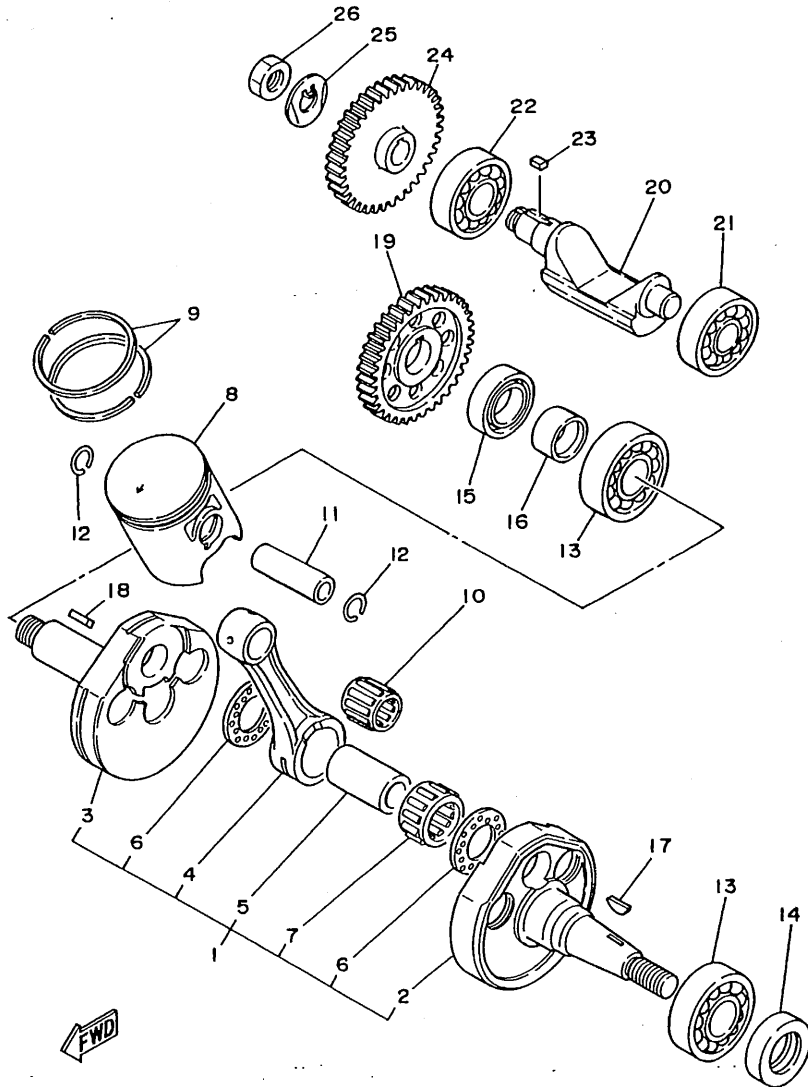

3MB1300-9020

REF. NO.	PART NO.	DESCRIPTION	Q'TY	REMARKS
1	3RM-11400-00	CRANKSHAFT ASSY	1	
2	3RM-11412-00	.CRANK 1	1	
3	3MB-11422-00	.CRANK 2	1	
4	2RH-11651-00	.ROD, connecting	1	
5	37F-11681-00	.PIN, crank 1	1	
6	90209-22257	.WASHER	2	
7	93310-523T3	.BEARING, cylindrical	1	
8	3MB-11631-01-95	PISTON (STD)	1	
	3MB-11635-01	PISTON (0.25MM O/S)	1	AP
	3MB-11636-01	PISTON (0.50MM O/S)	1	AP
9	3MB-11610-01	PISTON RING SET (STD)	1	
	3MB-11610-11	PISTON RING SET (1ST O/S)	1	AP
	3MB-11610-21	PISTON RING SET (2ND O/S)	1	AP
10	93310-316B4	BEARING, cylindrical	1	
11	3MB-11633-00	PIN, piston	1	
12	93450-17129	CIRCLIP	2	
13	93306-30556	BEARING	2	
14	93102-25331	OIL SEAL	1	
15	93103-32171	OIL SEAL	1	
16	90387-202T9	COLLAR	1	
17	90280-03045	KEY, woodruff	1	
18	90282-05047	KEY, straight	1	
19	10V-11536-01	GEAR, drive	1	
20	2RH-11454-00	WEIGHT 1	1	
21	93306-30210	BEARING	1	
22	93306-20335	BEARING	1	
23	90282-05058	KEY, straight	1	
24	55K-11530-00	BALANCER WIEGHT GEAR COMP.43T	1	

B3

FIG. 2 CRANKSHAFT. PISTON

REF. NO.	PART NO.	DESCRIPTION	Q'TY	REMARKS
25	90215-12272	WASHER, Lock	1	
26	90170-12370	NUT	1	

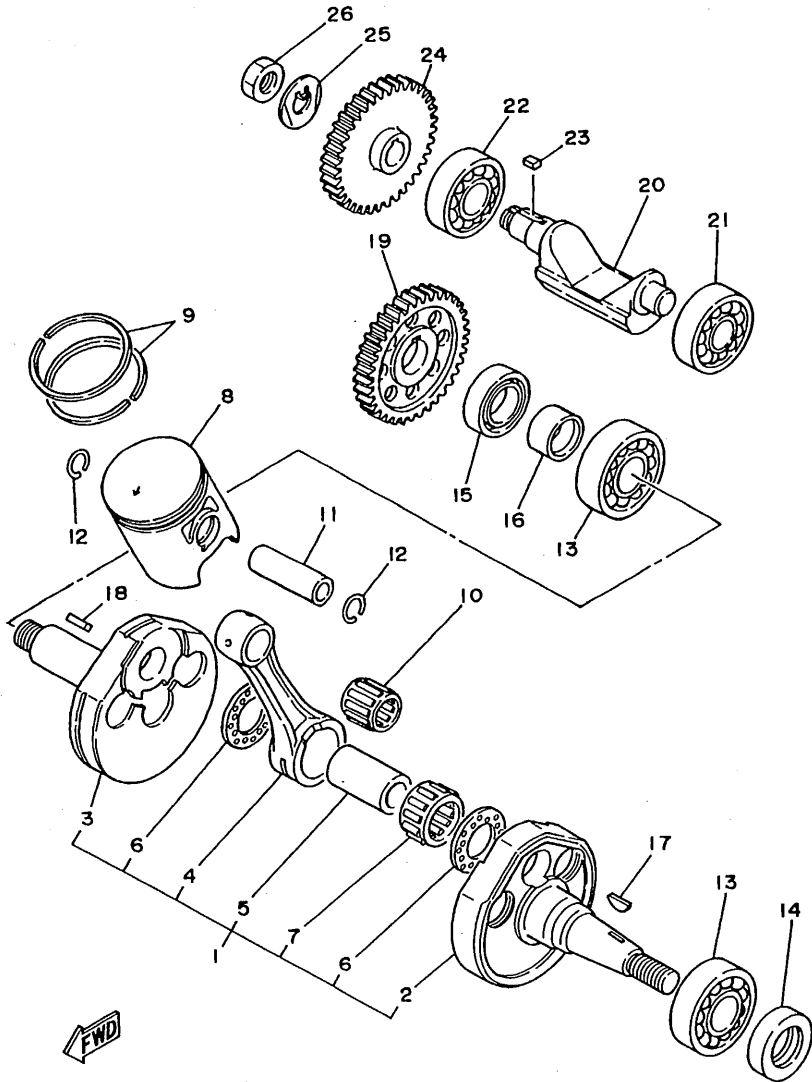

3MB1300-9020

**B4**

FIG. 3 WATER PUMP

REF. NO.	PART NO.	DESCRIPTION	Q'TY	REMARKS
1	36F-12450-00	IMPELLER SHAFT ASSY	1	
2	93103-10147	OIL SEAL	1	
3	93603-22028	PIN, dowel	1	
4	2RH-12459-00	GEAR, impeller shaft	1	
5	90201-08512	WASHER, plate	2	
6	99080-07600	CIRCLIP	1	
7	3BN-12422-11	COVER, housing	1	
8	3BN-12428-11	GASKET, housing cover 2	1	
9	93604-10011	PIN, dowel	2	
10	98501-06025	SCREW, pan head	1	
11	98501-06065	SCREW, pan head	1	
12	95811-06025	BOLT, flange	1	
13	90430-06166	GASKET	1	

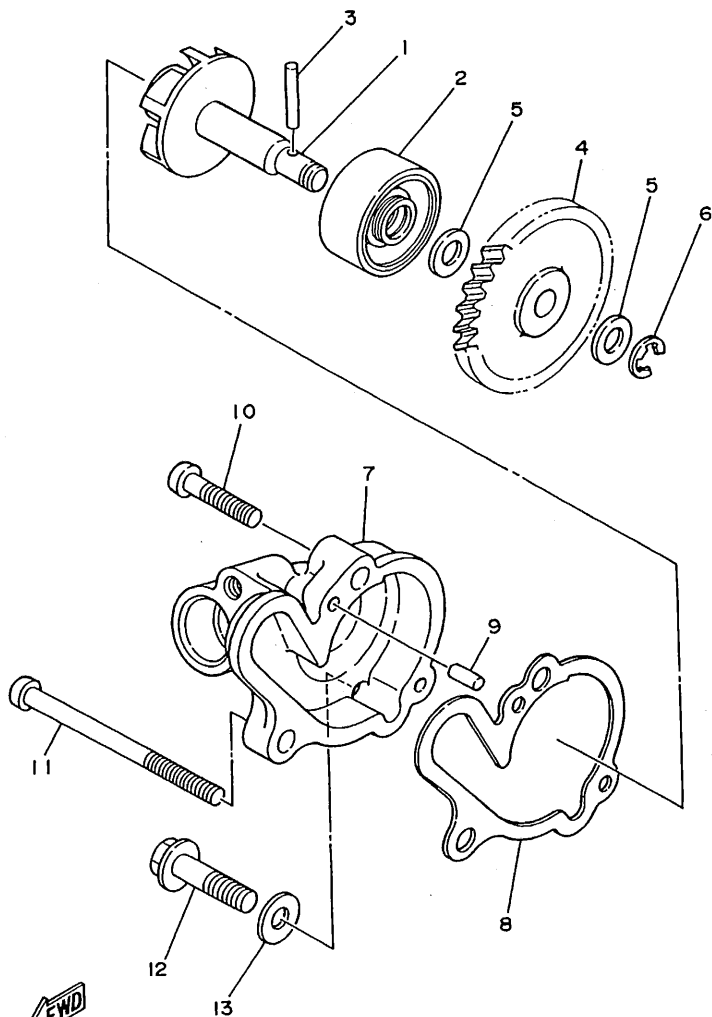

3BN300-8030

**B5**



FIG. 4 RADIATOR. HOSE

REF. NO.	PART NO.	DESCRIPTION	Q'TY	REMARKS
1	3BN-12469-00	JOINT 1	1	
2	3BN-12414-10	GASKET, cover	1	
3	98516-06020	SCREW, pan head	3	
4	3BN-12481-00	PIPE 1	1	
5	98501-06012	SCREW, pan head	1	
6	93210-12327	O-RING	1	
7	98501-06012	SCREW, pan head	1	
8	3BN-12482-00	PIPE 2	1	
9	90450-22052	HOSE CLAMP ASSY	2	
10	3BN-12483-00	PIPE 3	1	
11	90450-28014	HOSE CLAMP ASSY	2	
12	3BN-12460-00	RADIATOR ASSY	1	
13	1KT-12462-00	.CAP, radiator	1	
14	90480-15363	GROMMET	2	
15	91001-06020	BOLT, flange	2	
16	90387-07390	COLLAR	2	
17	90201-06072	WASHER, plate	2	
18	34X-12411-00	THERMOSTAT	1	
19	93210-27194	O-RING	1	
20	90430-06166	GASKET	2	
21	90401-06115	BOLT, union	1	
22	90405-06044	UNION	1	
23	2TV-12482-01	PIPE 6	1	
24	90467-10035	CLIP	2	
25	90405-06044	UNION	1	
26	2RH-12484-00	PIPE 4	1	
27	90467-10035	CLIP	2	
28	90430-06166	GASKET	2	

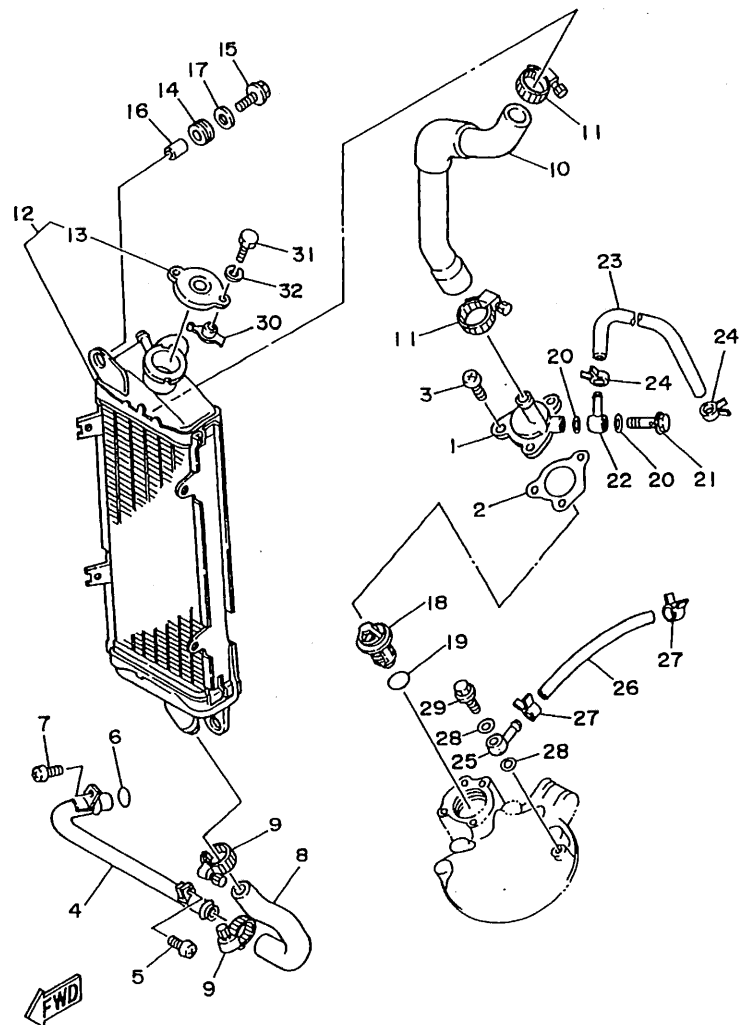

3RM3300-1040

**B6**

FIG. 4 RADIATOR. HOSE

REF. NO.	PART NO.	DESCRIPTION	Q'TY	REMARKS
29	90401-06115	BOLT, union	1	
30	1KT-12437-00	STOPPER	1	
31	97006-05012	BOLT	1	
32	92906-05100	WASHER, spring	1	

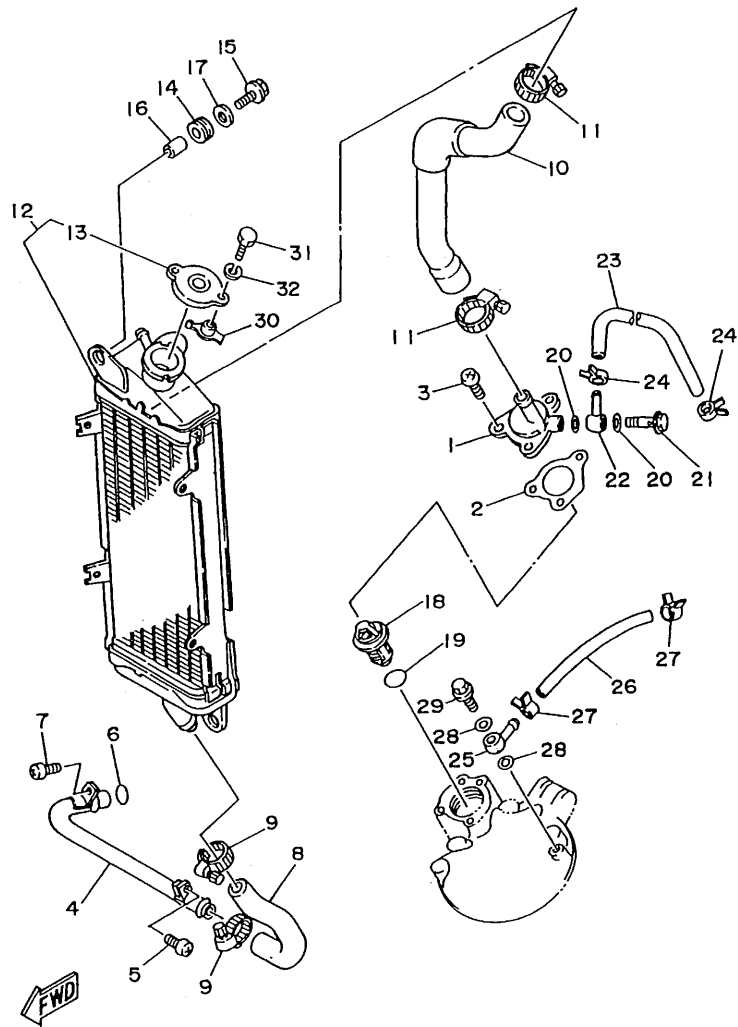

3RM3300-1040

**B7**

FIG. 5 OIL PUMP

REF. NO.	PART NO.	DESCRIPTION	Q'TY	REMARKS
1	3MB-13101-01	OIL PUMP ASSY	1	
2	90445-057F9	.HOSE	1	
3	353-13552-01	.NOZZLE	2	
4	90468-02033	.CLIP	1	
5	93505-32002	.BALL	1	
6	90501-02217	.SPRING, compression	1	
7	90430-04004	.GASKET	1	
8	98906-04006	.SCREW, bind	1	
9	137-13138-01	.PLATE, adjusting	1	
10	137-13137-00-10	.SHIM (1.0T)	1	UN
11	92901-05100	.WASHER, spring	1	
12	95303-05600	.NUT	1	
13	55K-13175-01	SHAFT, worm	1	
14	90201-08624	WASHER, plate	1	
15	3MT-13116-00	GASKET, pump case	1	
16	98580-05014	SCREW, pan head	2	
17	93101-10090	OIL SEAL	1	
18	1E7-13176-00	METAL, worm shaft outer	1	
19	10V-13178-01	GEAR, pump drive	1	
20	93603-22028	PIN, dowel	1	
21	93430-08036	CIRCLIP	2	
22	363-13133-01	CLIP	1	
23	90468-02033	CLIP	1	
24	3BN-13174-00	HOLDER, oil pipe	1	
25	93210-07100	O-RING	1	
26	90468-08086	CLIP	1	

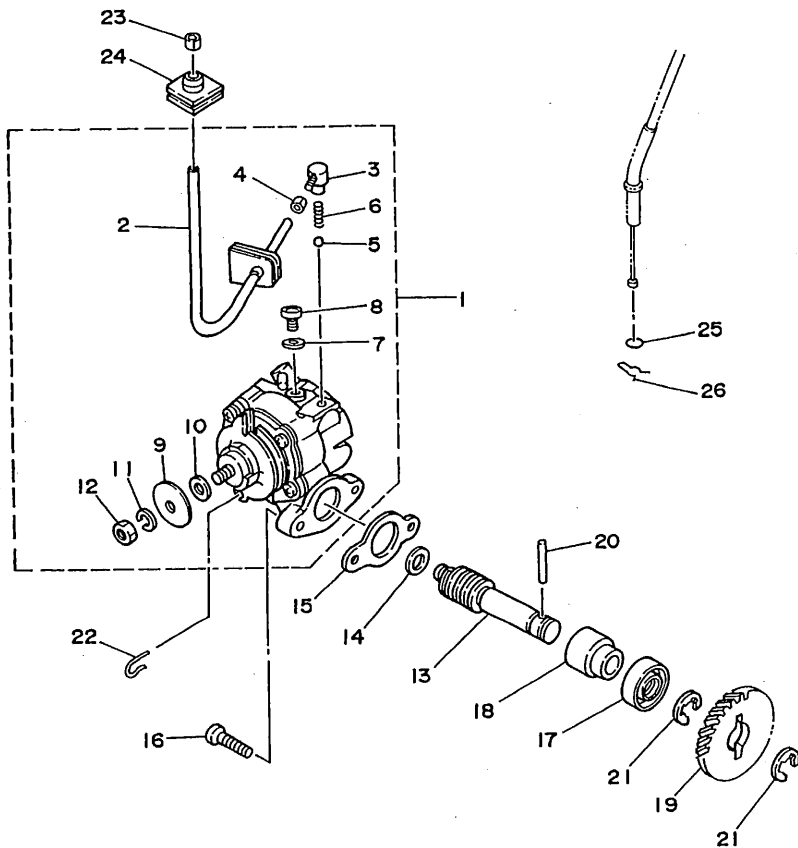

3BN300-8050

**B8**

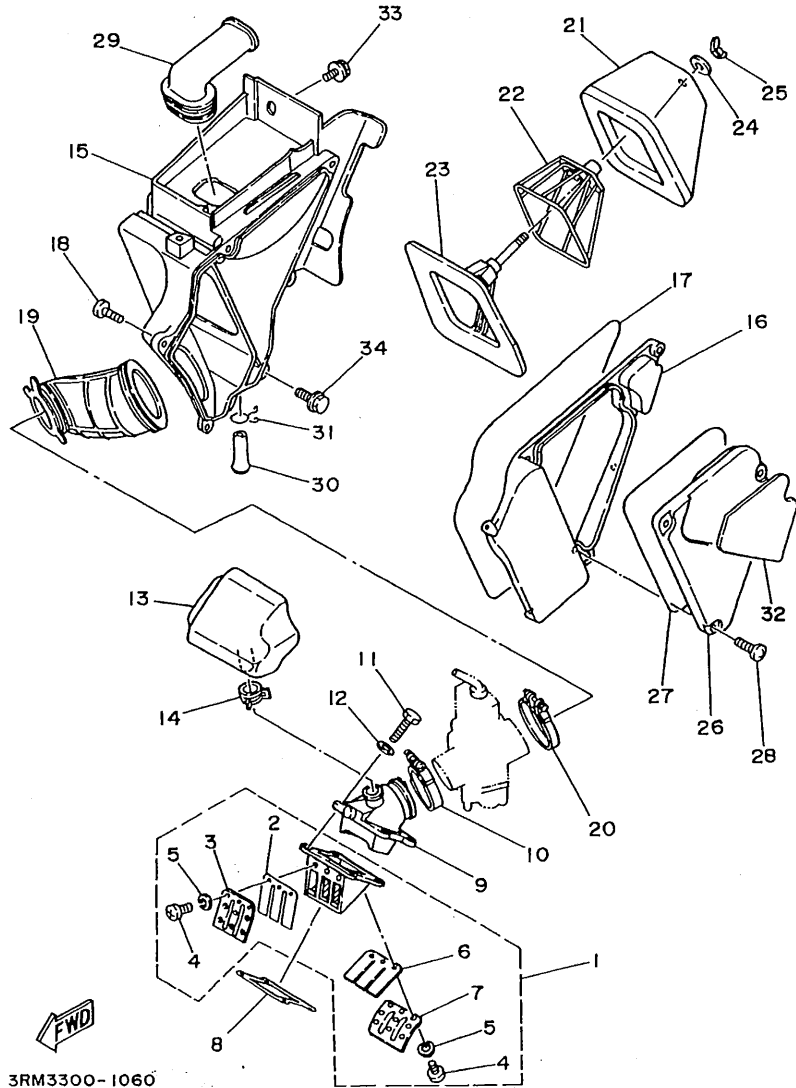

3RM3300-1060

FIG. 6 INTAKE

REF. NO.	PART NO.	DESCRIPTION	Q'TY	REMARKS
1	3MB-13610-00	REED VALVE ASSY	1	
2	2TV-13613-00	.REED, valve	1	
3	3BN-13616-00	.STOPPER, reed valve	1	
4	98580-03008	.SCREW, pan head	6	
5	92990-03100	.WASHER, spring	6	
6	3MB-13613-00	.REED, valve	1	
7	3MB-13616-00	.STOPPER, reed valve	1	
8	1KT-13621-01	GASKET, valve seat	1	
9	3ET-13565-00	JOINT, carburetor	1	
10	90450-44046	HOSE CLAMP ASSY	1	
11	97001-06025	BOLT	4	
12	92906-06600	WASHER, plate	4	
13	3ET-13581-00	CHAMBER, air	1	
14	90467-20050	CLIP	1	
15	3BN-14411-00	CASE, air cleaner 1	1	
16	3BN-14421-00	CASE, air cleaner 2	1	
17	3BN-14452-00	SEAL	1	
18	97706-50520	SCREW, tapping	6	
19	3MB-14453-00	JOINT, air cleaner 1	1	
20	1AE-13575-00	BAND	1	
21	3BN-14451-01	ELEMENT, air cleaner	1	
22	3BN-14458-00	GUIDE	1	
23	3BN-14459-00	HOLDER, guide	1	
24	90209-06096	WASHER	1	
25	90175-06012	NUT, wing	1	
26	3BN-14412-00	CAP, cleaner case 1	1	
27	3BN-14467-00	SEAL	1	
28	90154-05011	SCREW, binding	3	

B9

FIG. 6 INTAKE

REF. NO.	PART NO.	DESCRIPTION	Q'TY	REMARKS
29	3ET-14437-00	DUCT	1	
30	34X-1443E-00	PIPE, drain	1	
31	90467-11102	CLIP	1	
32	38N-14425-00	DAMPER 1	1	
33	90119-06056	BOLT, with washer	1	
34	90119-06123	BOLT, with washer	1	

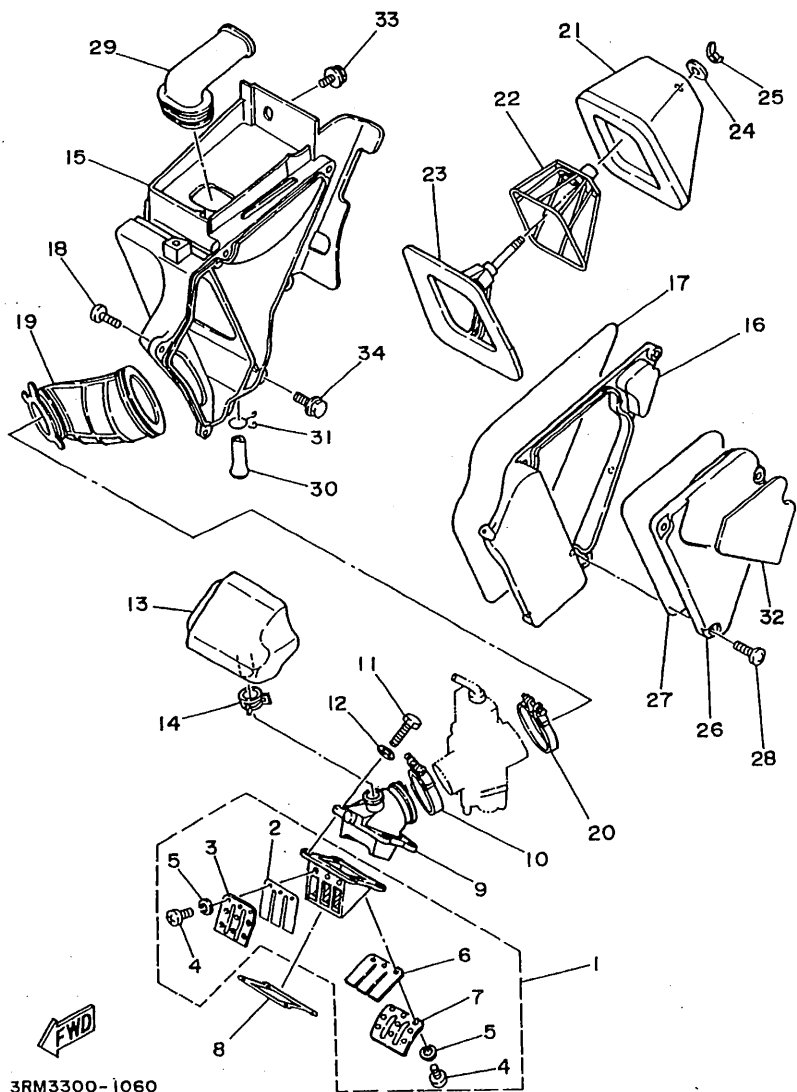

3RM3300-1060

B10

FIG. 7 CARBURETOR

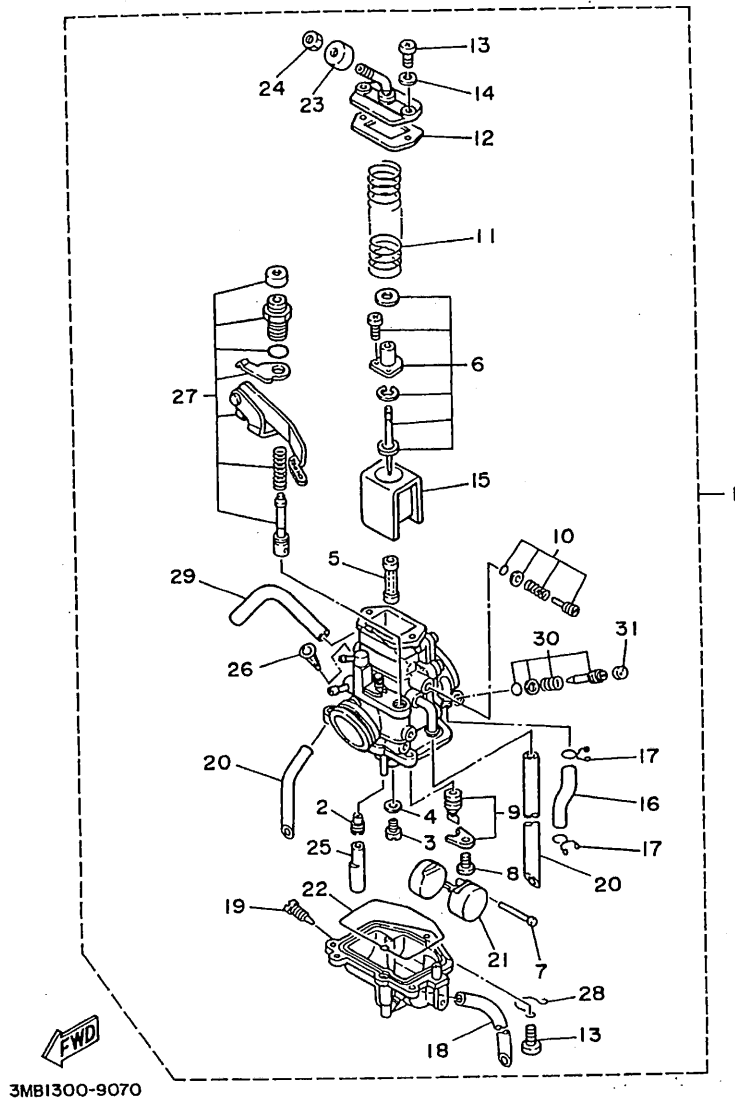

REF. NO.	PART NO.	DESCRIPTION	Q'TY	REMARKS
1	3MB-14101-00	CARBURETOR ASSY 1	1	
2	193-14142-22	.JET, pilot (# 22.5)	1	
3	137-14143-42-A0	.JET, main (#210)	1	
4	137-14153-00	.WASHER, main jet	1	
5	1KT-14141-52	.NOZZLE, main	1	
6	3ME-1490J-00	.NEEDLE SET	1	
7	537-14186-00	.PIN, float	1	
8	98580-04008	.SCREW, pan head	1	
9	2MA-14107-28	.NEEDLE VALVE SET	1	
10	3ET-14103-00	.THROTTLE SCREW SET	1	
11	1KT-14131-00	.SPRING, throttle valve	1	
12	1KT-14198-00	.GASKET	1	
13	98503-04014	.SCREW, pan head	5	
14	92902-04100	.WASHER, spring	2	
15	2TV-14112-25	.VALVE, throttle 1	1	
16	90445-07747	.HOSE	1	
17	8A7-14139-00	.CLIP, pipe	2	
18	3X3-14197-00	.PIPE	1	
19	12R-14191-00	.PLUG, drain	1	
20	3MB-14197-00	.PIPE	2	
21	2MA-14185-00	.FLOAT	1	
22	1KT-14147-00	.O-RING	1	
23	3X3-14169-00	.CAP	1	
24	127-14161-00	.NUT, cable adjusting	1	
25	3ET-14153-00	.WASHER, main jet	1	
26	1KT-14994-00	.NET, filter	1	
27	3ET-1410A-00	.STARTER SET	1	
28	25G-14937-00	.CLIP	1	

**B11**

FIG. 7 CARBURETOR

REF. NO.	PART NO.	DESCRIPTION	Q'TY	REMARKS
29	493-14196-00	.PIPE	1	
30	3ME-14104-00	.AIR SCREW SET	1	
31	2RJ-14118-00	.CAP	1	

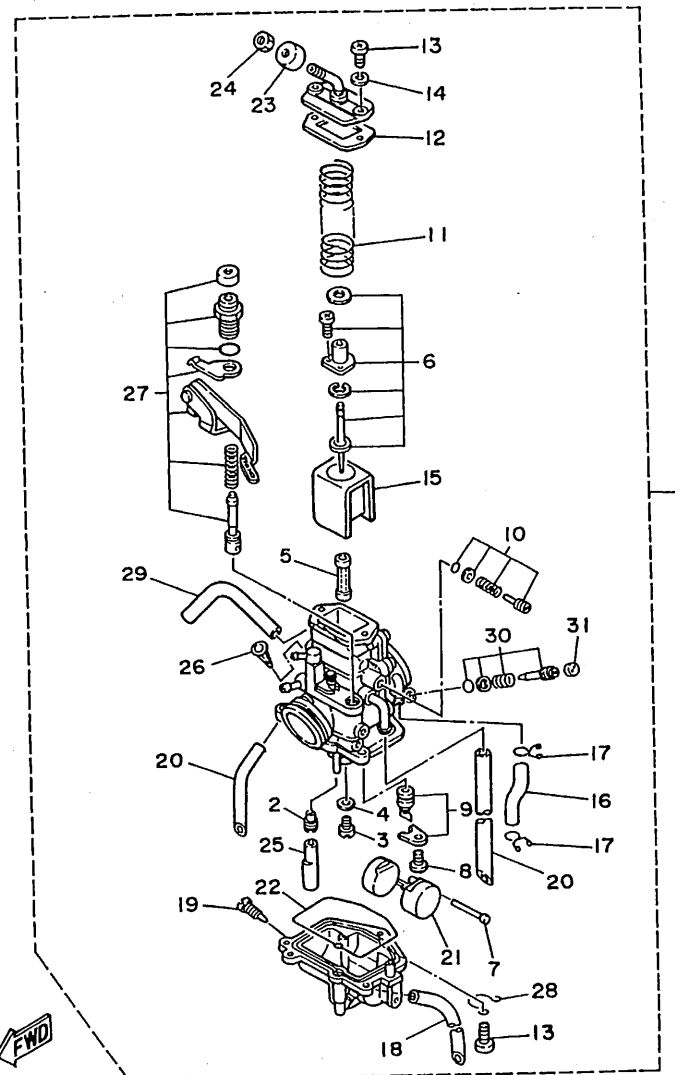

3MB1300-9070

**B12**

FIG. 8 EXHAUST

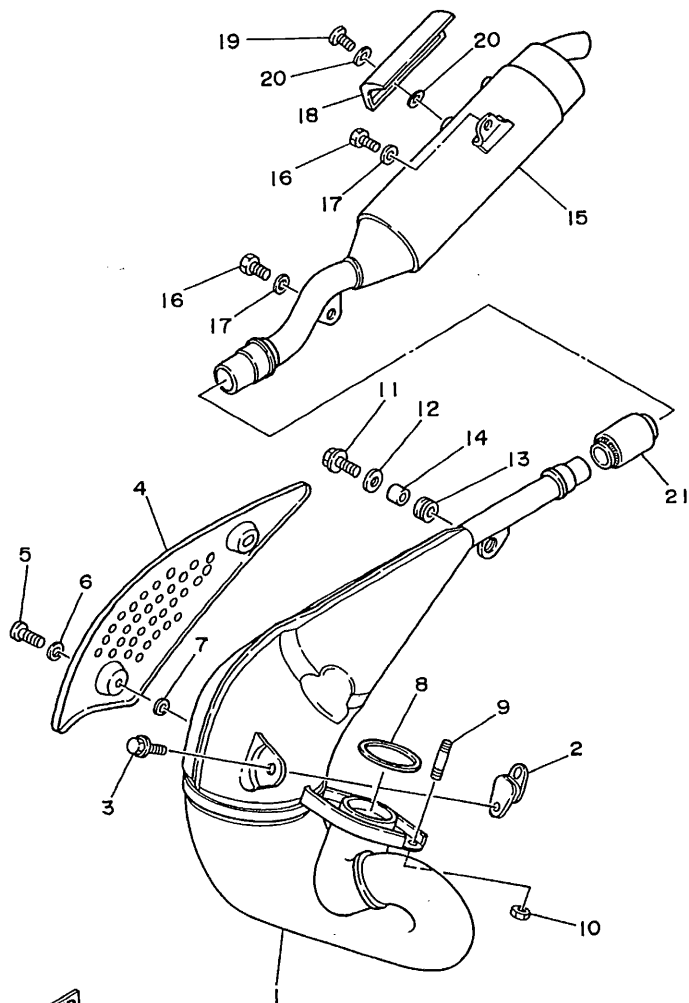

REF. NO.	PART NO.	DESCRIPTION	Q'TY	REMARKS
1	3MB-14610-01	EXHAUST PIPE ASSY 1	1	
2	565-14771-00	STAY, muffler 1	1	
3	95816-06012	BOLT, flange	2	
4	3BN-14718-00	PROTECTOR, muffler 1	1	
5	98906-06010	SCREW, bind	2	
6	90202-05187	WASHER, plate	2	
7	90202-05188	WASHER, plate	2	
8	3PA-14613-10	GASKET, exhaust pipe	1	
9	90116-08042	BOLT, stud	2	
10	90179-08270	NUT	2	
11	95816-06025	BOLT, flange	1	
12	90201-060A3	WASHER, plate	1	
13	90480-18411	GROMMET	1	
14	90387-105L0	COLLAR	1	
15	3MB-14753-00	SILENCER, exhaust	1	
16	90109-085E3	BOLT	2	
17	90201-081H4	WASHER, plate	2	
18	3BN-14758-00	PROTECTOR, silencer	1	
19	98906-06008	SCREW, bind	2	
20	90202-05187	WASHER, plate	4	
21	2YK-14714-00	GASKET, muffler	1	

FWD

3MB1300-9080

B13



FIG. 9 CRANKCASE

REF. NO.	PART NO.	DESCRIPTION	Q'TY	REMARKS
1	3BN-15111-03	CRANKCASE 1	1	
2	3BN-15121-02	CRANKCASE 2	1	
3	90201-170M2	WASHER, plate	2	
4	328-15316-00	DAMPER, engine mount 1	2	
5	3BN-15317-00	SPACER, engine mount	1	
6	93210-12154	O-RING	2	
7	99510-12016	PIN, dowel	2	
8	98501-06060	SCREW, pan head	4	
9	98501-06065	SCREW, pan head	1	
10	98501-06050	SCREW, pan head	5	
11	98501-06070	SCREW, pan head	2	
12	98501-06040	SCREW, pan head	1	
13	3BN-15199-01	BRACKET	1	
14	583-15371-00	BREATHER	1	
15	90446-07349	HOSE	1	
16	37F-15128-00	HOLDER	1	
17	98511-08010	SCREW, pan head	1	
18	2RH-15492-00	COVER	1	
19	98502-06012	SCREW, pan head	2	

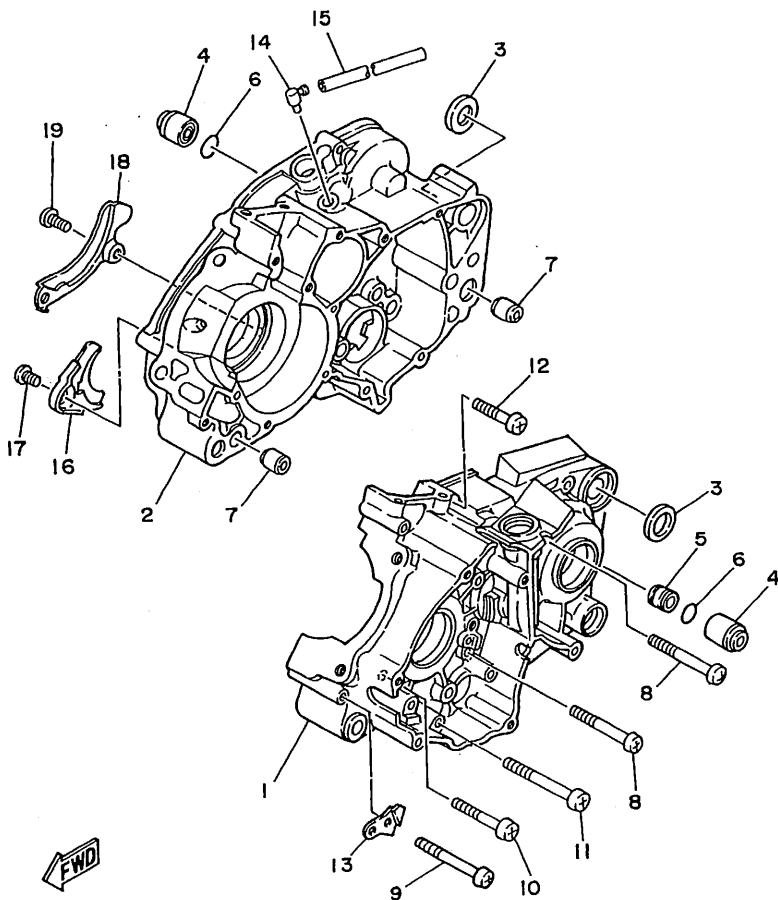

3BN300-8090

**B14**

FIG. 10 CRANKCASE COVER 1

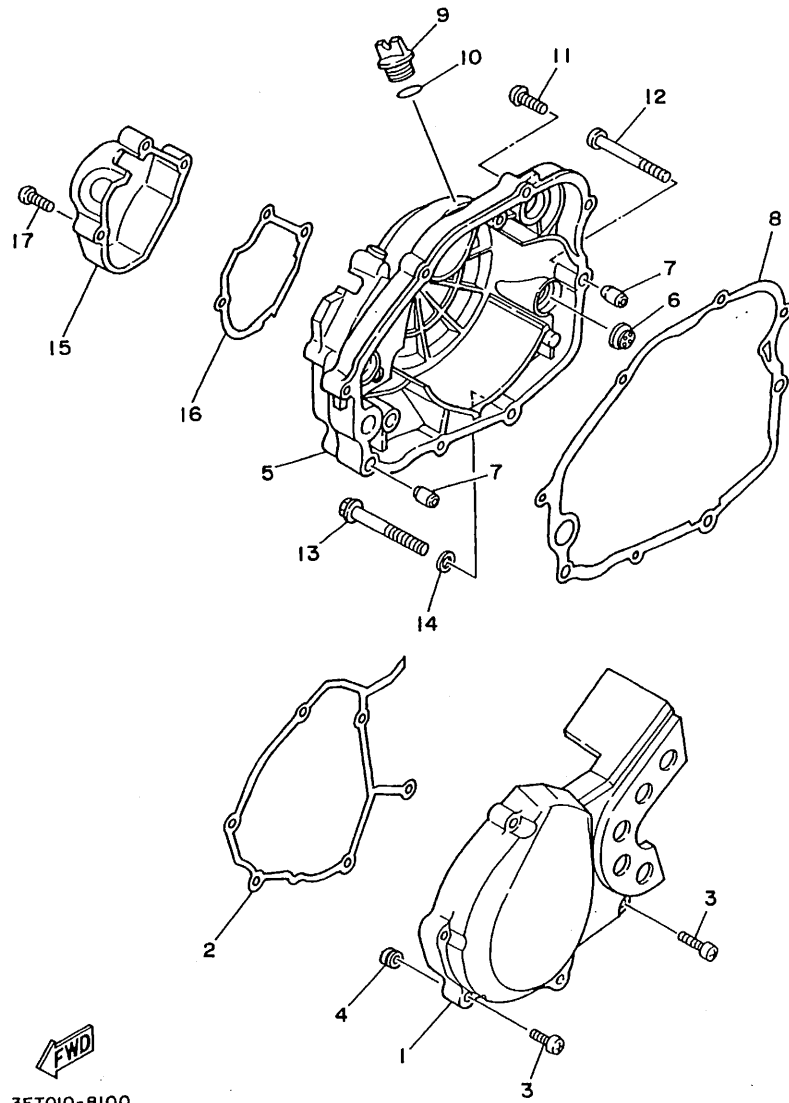

REF. NO.	PART NO.	DESCRIPTION	Q'TY	REMARKS
1	3BN-15411-10	COVER, crankcase 1	1	
2	3ET-15379-00	SEAL, crankcase	1	
3	90157-06115	SCREW, pan head	6	
4	90480-09481	GROMMET	6	
5	3BN-15421-10	COVER, crankcase 2	1	
6	3Y1-15361-00	GAUGE, level	1	
7	99530-10014	PIN, dowel	2	
8	3BN-15451-10	GASKET, crankcase cover 1	1	
9	1RG-15363-00	PLUG, oil	1	
10	93210-19123	O-RING	1	
11	98501-06030	SCREW, pan head	5	
12	98501-06040	SCREW, pan head	1	
13	95801-08080	BOLT, flange	1	
14	90201-08087	WASHER, plate	1	
15	3BN-15416-10	COVER, oil pump	1	
16	3BN-15456-10	GASKET, oil pump cover 1	1	
17	98501-06030	SCREW, pan head	3	

FWD  
3ETO10-8100

B15

FIG. 11 STARTER

REF. NO.	PART NO.	DESCRIPTION	Q'TY	REMARKS
1	10V-15660-00	KICK AXLE ASSY	1	
2	10V-15641-00	GEAR, kick (23T)	1	
3	90468-26048	CLIP	1	
4	90201-200J7	WASHER, plate	1	
5	90508-26667	SPRING, torsion	1	
6	10V-15666-00	SPACER	1	
7	10V-15651-00	GEAR, kick idle (29T)	1	
8	90201-154E8	WASHER, plate	2	
9	93440-15012	CIRCLIP	2	
10	3BN-15620-00	KICK CRANK ASSY	1	
11	10V-15621-01	.BOSS, kick crank	1	
12	90501-12081	.SPRING, compression	1	
13	93507-32031	.BALL	1	
14	90201-12631	.WASHER, plate	1	
15	93430-08042	.CIRCLIP	1	
16	156-15618-01	.COVER, kick lever	1	
17	90179-12374	NUT	1	
18	93102-20309	OIL SEAL	1	

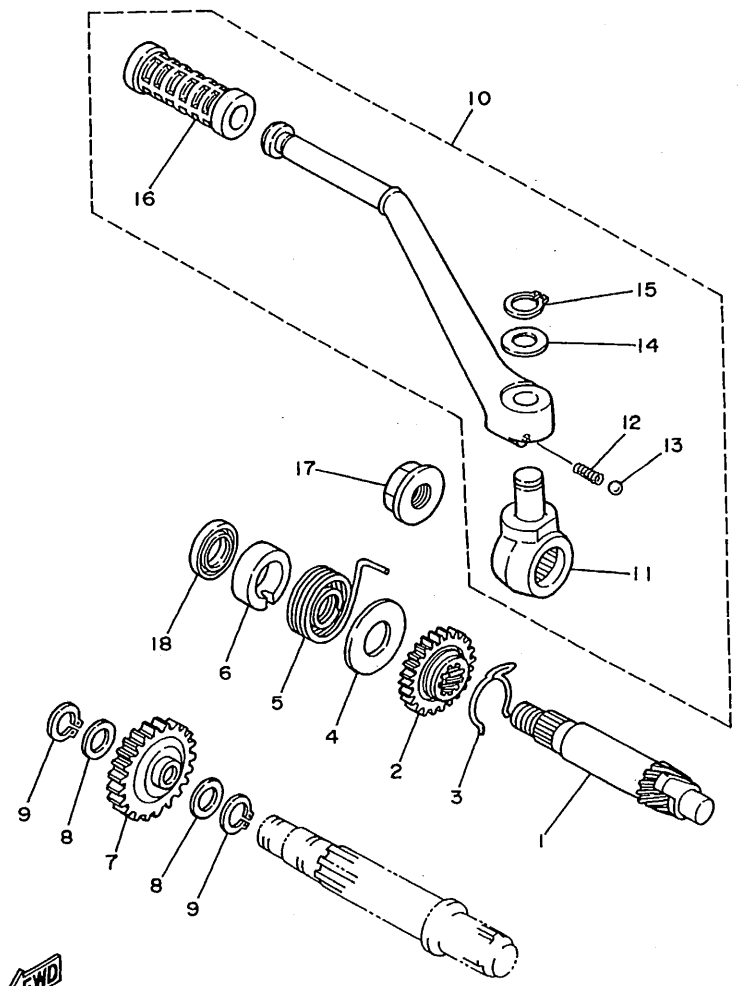

3BN300-8110

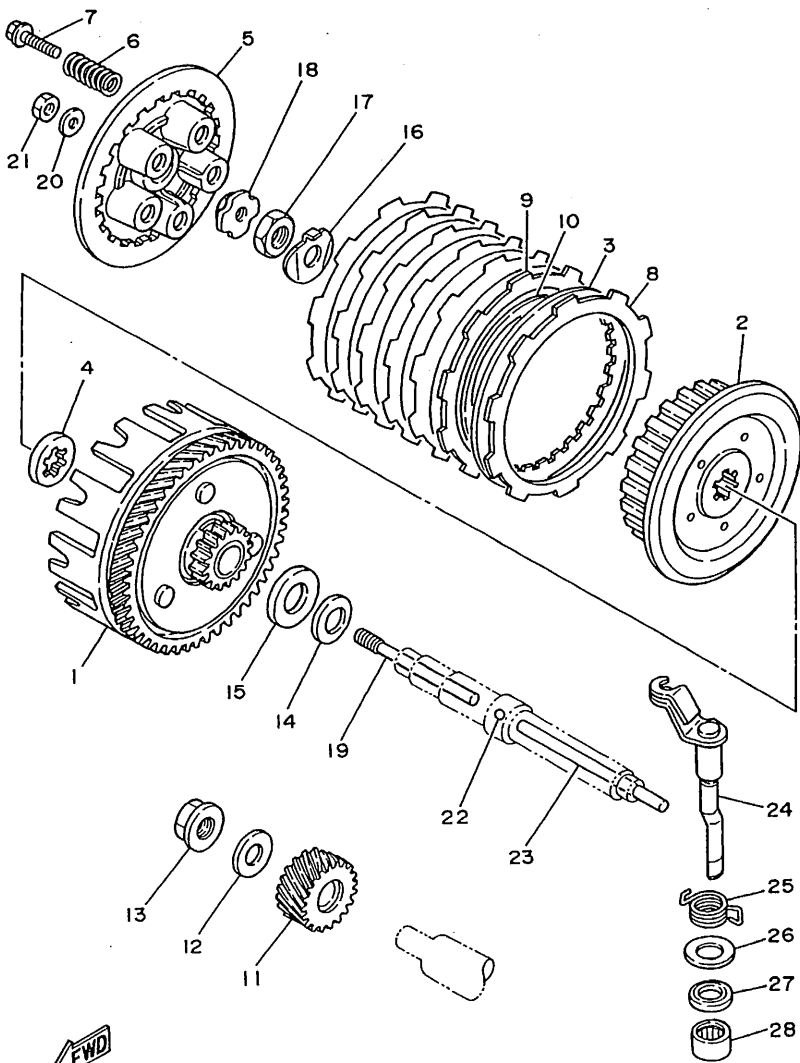

FIG. 12 CLUTCH

REF. NO.	PART NO.	DESCRIPTION	Q'TY	REMARKS
1	3BN-16150-01	PRIMARY DRIVEN GEAR COMP.	1	
2	2TV-16371-00	BOSS, clutch	1	
3	1V1-16324-00	PLATE, clutch 1	6	
4	2TV-16154-00	PLATE, thrust 1	1	
5	37F-16351-00	PLATE, pressure 1	1	
6	90501-20644	SPRING, compression	5	
7	90119-05001	BOLT, with washer	5	
8	21V-16321-00	PLATE, friction	6	
9	1HX-16331-00	PLATE, friction 2	1	
10	3BN-16383-00	SPRING, clutch boss	1	
11	2A6-16111-00	GEAR, primary drive (22T)	1	
12	90201-120E8	WASHER, plate	1	
13	90179-12244	NUT	1	
14	90208-18046	WASHER, conical spring	1	
15	90201-180P2	WASHER, plate	1	
16	90215-12271	WASHER, lock	1	
17	90170-12370	NUT	1	
18	30X-16358-00	PLATE, push	1	
19	1W1-16356-02	ROD, push 1	1	
20	92901-06200	WASHER, plain	1	
21	95303-06600	NUT	1	
22	93503-16010	BALL	1	
23	3R1-16357-00	ROD, push 2	1	
24	3BN-16380-00	PUSH LEVER ASSY	1	
25	90508-18765	SPRING, torsion	1	
26	90201-14217	WASHER, plate	1	
27	93104-14004	OIL SEAL	1	
28	93315-21429	BEARING, cylindrical	1	

FWD  
3BN300-8120

C3

FIG. 13 TRANSMISSION

REF. NO.	PART NO.	DESCRIPTION	Q'TY	REMARKS
1	3MB-17411-01	AXLE, main	1	
2	3BN-17121-00	GEAR, 2nd pinion (16T)	1	
3	3BN-17131-01	GEAR, 3rd pinion	1	
4	3BN-17151-01	GEAR, 5th pinion (23T)	1	
5	3MB-17161-00	GEAR, 6th pinion	1	
6	90201-20266	WASHER, plate (1.0T)	2	
7	93410-20038	CIRCLIP	3	
8	93306-20431	BEARING (B6204Z)	1	
9	93311-31567	BEARING, cylindrical	1	
10	3BN-17421-00	AXLE, drive	1	
11	2TV-17211-01	GEAR, 1st wheel (34T)	1	
12	3BN-17221-00	GEAR, 2nd wheel (30T)	1	
13	3BN-17231-01	GEAR, 3rd wheel (24T)	1	
14	3XP-17241-00	GEAR, 4th wheel (24T)	1	
15	3BN-17251-02	GEAR, 5th wheel (22T)	1	
16	3XP-17261-00	GEAR, 6th wheel (18T)	1	
17	90201-154E8	WASHER, plate	1	
18	99009-15400	CIRCLIP	1	
19	90209-18135	WASHER	2	
20	93410-22039	CIRCLIP	4	
21	90201-22555	WASHER, plate	1	
22	93306-20201	BEARING (B6202)	1	
23	93306-30438	BEARING	1	
24	93102-26042	OIL SEAL	1	
25	90387-205U0	COLLAR	1	
26	3RM-17460-00	SPROCKET, drive (16T)	1	
27	90215-20283	WASHER, lock	1	
28	90179-16226	NUT	1	

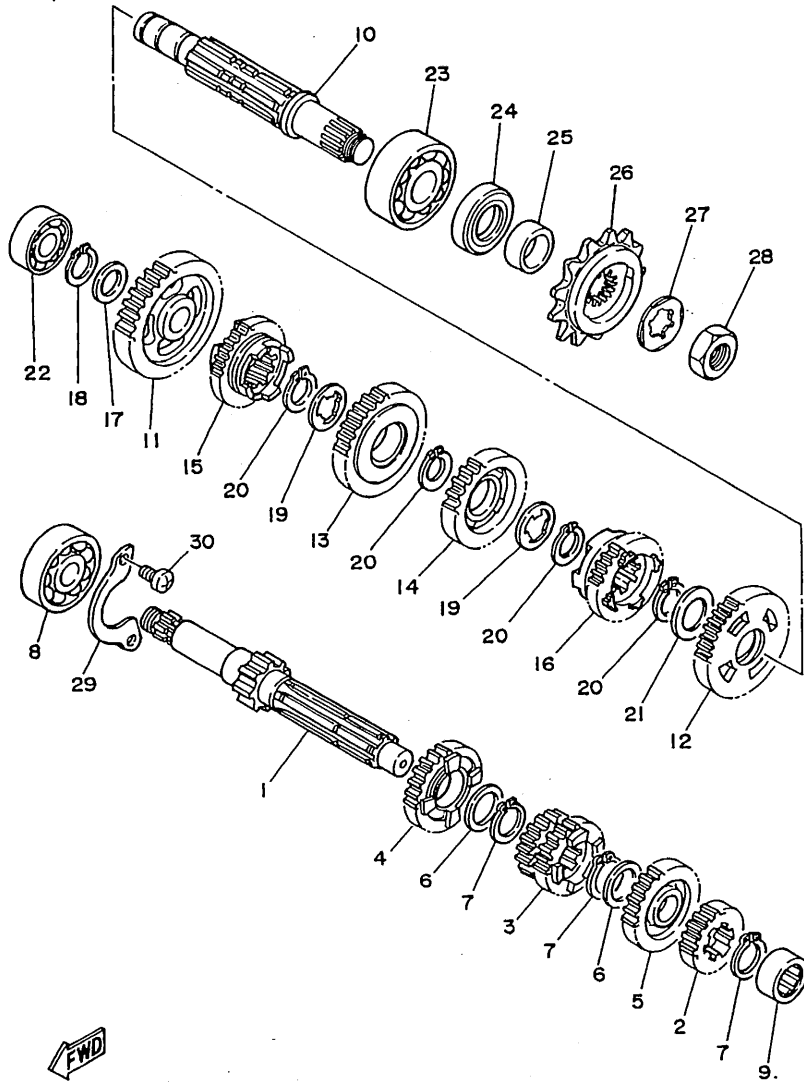

3MB1300-9140

C4

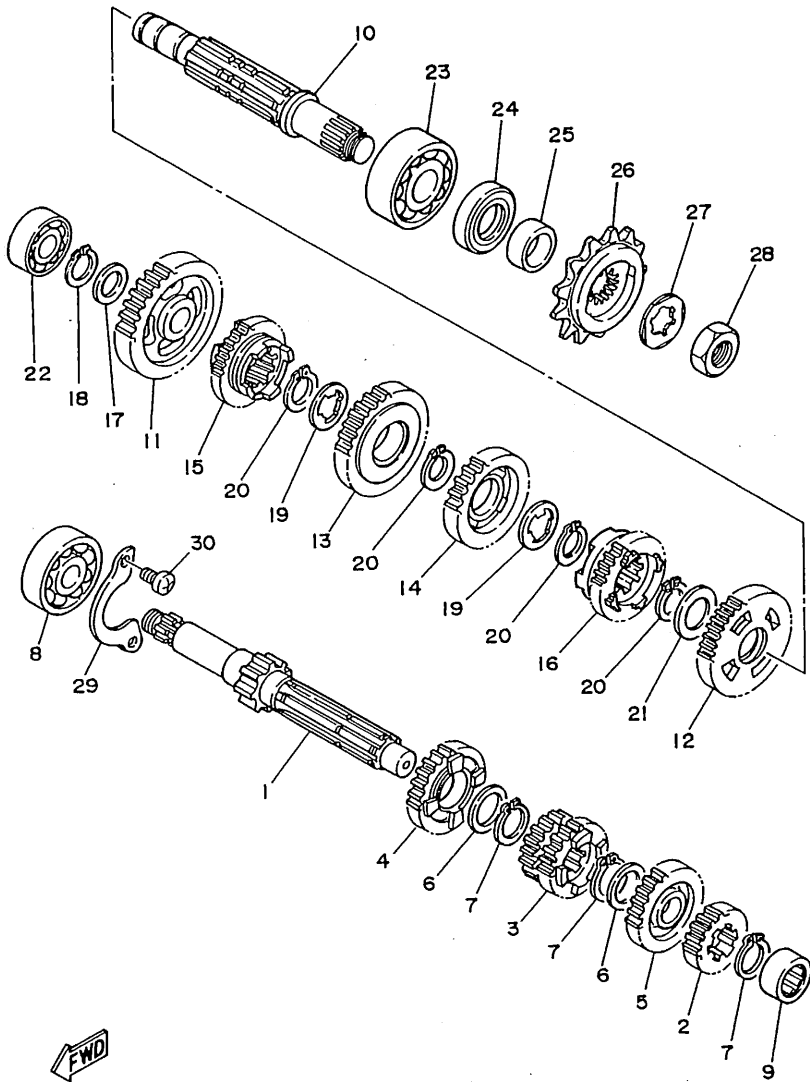

FIG. 13 TRANSMISSION

REF. NO.	PART NO.	DESCRIPTION	Q'TY	REMARKS
29	55K-17471-00	PLATE, cover	1	
30	98501-06012	SCREW, pan head	2	



3MB1300-9140

C5

FIG. 14 TACHOMETER GEAR

REF. NO.	PART NO.	DESCRIPTION	Q'TY	REMARKS
1	17F-17861-00	AXLE, drive gear	1	
2	17F-17831-00	GEAR, drive	1	
3	17F-17841-00	GEAR, driven	1	
4	90201-087H6	WASHER, plate	2	
5	4L0-17811-00	HOUSING, tachometer gear	1	
6	93210-12327	O-RING	1	
7	4L0-17818-00	GASKET	1	
8	97006-06010	BOLT	1	
9	92906-06600	WASHER, plate	1	

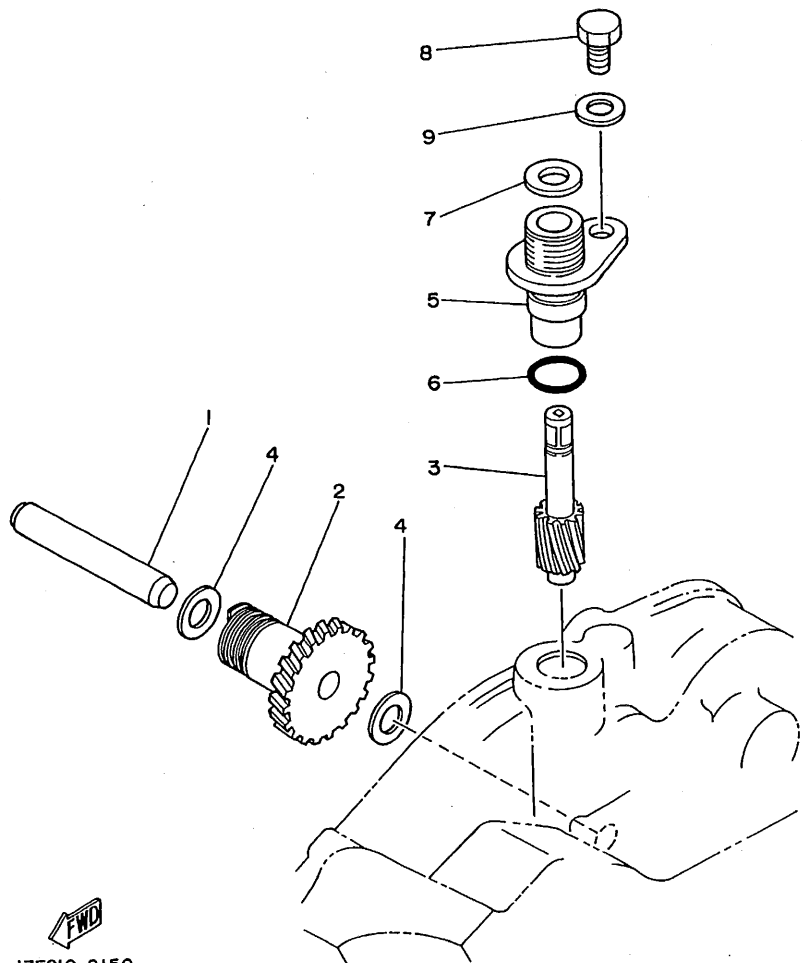

17F010-2150

C6

FIG. 15 SHIFT CAM. FORK

REF. NO.	PART NO.	DESCRIPTION	Q'TY	REMARKS
1	3XP-18540-00	SHIFT CAM ASSY	1	
2	3BN-18140-00	STOPPER LEVER ASSY	1	
3	90508-26561	SPRING, torsion	1	
4	90109-063F7	BOLT	1	
5	55K-18511-01	FORK, shift 1	1	
6	2RH-18512-00	FORK, shift 2	1	
7	55K-18513-00	FORK, shift 3	1	
8	55K-18531-00	BAR, shift fork guide 1	1	
9	3BN-18535-00	BAR, shift fork guide 2	1	
10	99009-10400	CIRCLIP	1	

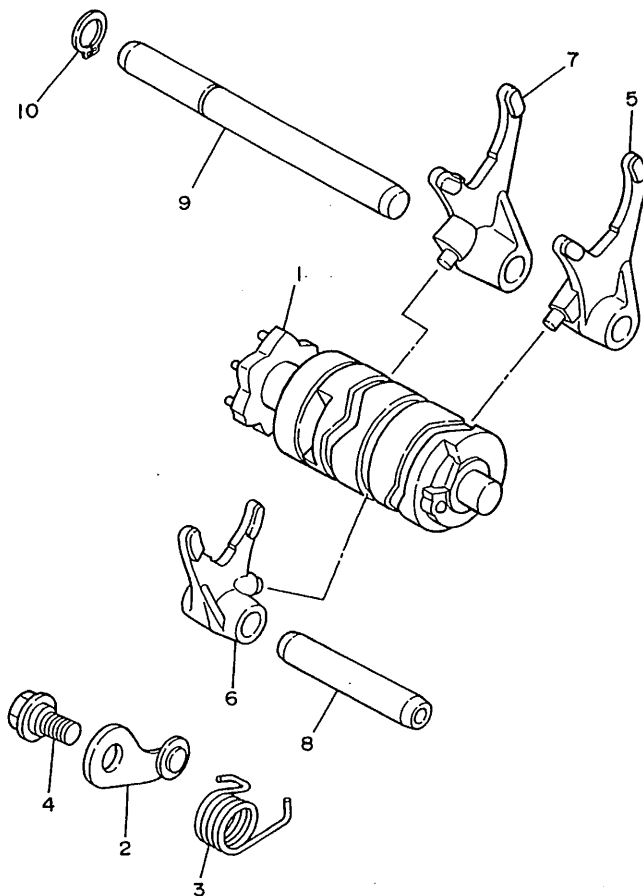

3BN300-8150

C7



FIG. 16 SHIFT SHAFT

REF. NO.	PART NO.	DESCRIPTION	Q'TY	REMARKS
1	10W-18101-03	SHIFT SHAFT ASSY	1	
2	93101-12060	OIL SEAL	1	
3	90508-32553	SPRING, torsion	1	
4	99006-10600	CIRCLIP	1	
5	3BN-18110-00	SHIFT PEDAL ASSY	1	
6	1W6-18113-00	.COVER, shift pedal	1	
7	97016-06020	BOLT	1	

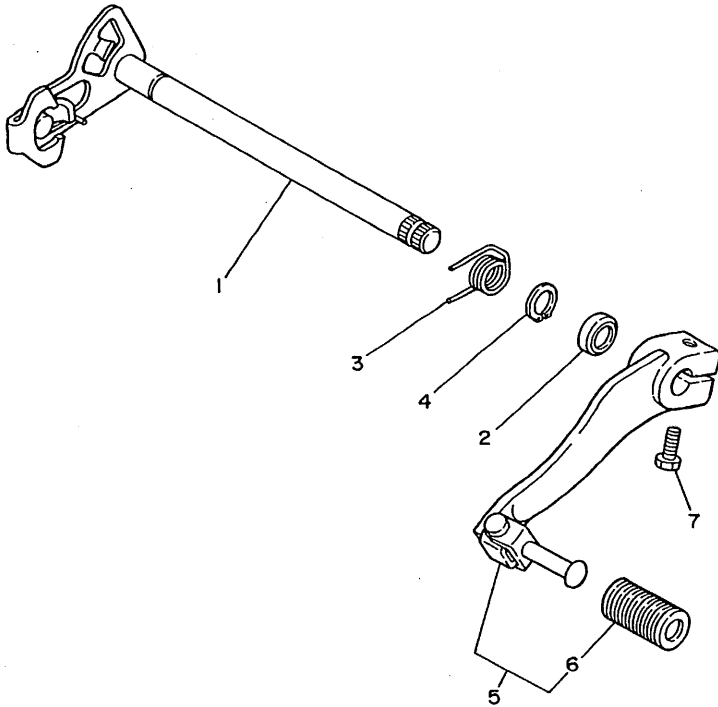

3BN300-8160

C8

FIG. 17 FRAME

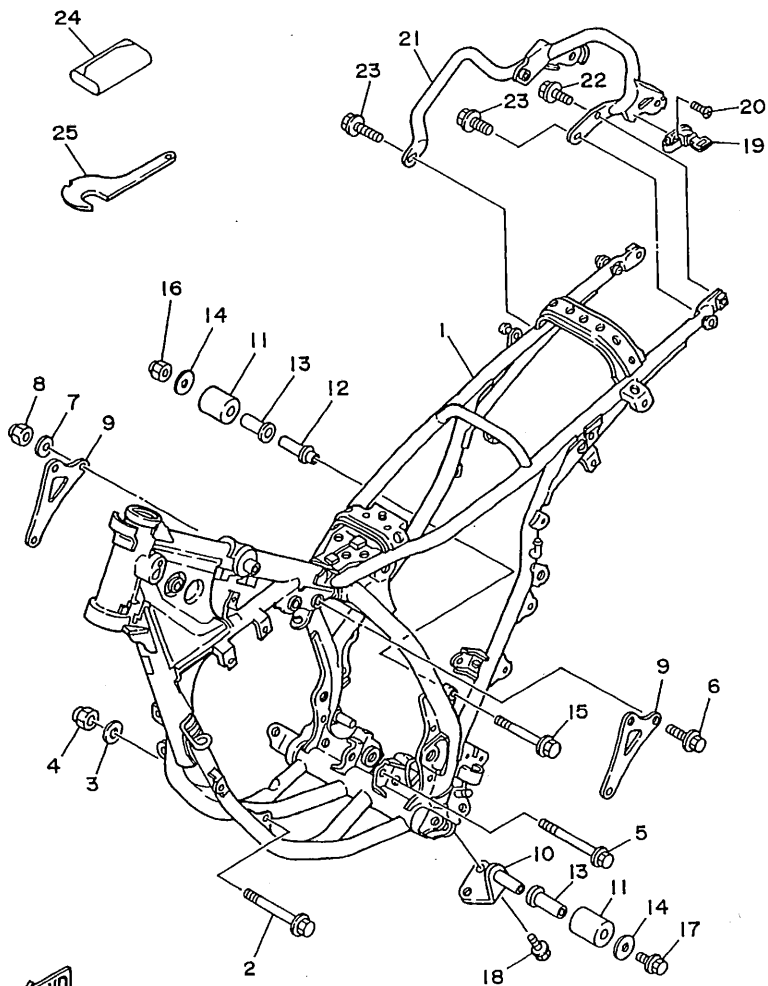

REF. NO.	PART NO.	DESCRIPTION	Q'TY	REMARKS
1	3RN-21110-00-UJ	FRAME COMP.	1	UR RADICAL WHITE
	3RN-21110-00-33	FRAME COMP.	1	UR YAMAHA BLACK
2	90105-10052	BOLT, washer based	1	
3	90201-100E9	WASHER, plate	1	
4	90185-10060	NUT, self-locking	1	
5	90105-08391	BOLT, washer based	1	
6	95811-08045	BOLT, flange	3	
7	90201-094G1	WASHER, plate	3	
8	90185-08089	NUT, self-locking	3	
9	3BN-21425-00	BRACKET, rear upper 1	2	
10	3BN-2141E-00	BRACKET 2	1	
11	30X-22178-00	TENSIONER	2	
12	2K7-2148A-00	SHAFT	1	
13	10V-22184-00	BUSH	2	
14	90201-08753	WASHER, plate	2	
15	95816-08050	BOLT, flange	1	
16	90185-08143	NUT, self-locking	1	
17	95026-08012	BOLT, flange	1	
18	95816-06012	BOLT, flange	2	
19	55E-21308-00	HELMET HANGER ASSY	1	
20	90151-06025	SCREW, countersunk	1	
21	3BN-21190-00-UJ	REAR FRAME COMP.	1	UR RADICAL WHITE
	3BN-21190-00-33	REAR FRAME COMP.	1	UR YAMAHA BLACK
22	90119-06172	BOLT, with washer	2	
23	95811-06012	BOLT, flange	2	
24	3BN-28100-00	TOOL KIT	1	
25	10V-28135-00	SPANNER, special	1	

3RPI361-9170

FIG. 18 FENDER

REF. NO.	PART NO.	DESCRIPTION	Q'TY	REMARKS
1	3XJ-21511-01	FENDER, front	1	UR PURPLISH WHITE SOLID 1
	28K-21511-11	FENDER, front	1	UR YAMAHA BLACK
	3BN-21511-40	FENDER, front	1	UR PASTEL MINERAL BLUE
2	90119-06097	BOLT, with washer	4	
3	90387-062V8	COLLAR	4	
4	3BN-21611-40	FENDER, rear	1	UR PURPLISH WHITE SOLID 1
	3BN-21611-10	FENDER, rear	1	UR YAMAHA BLACK
	3BN-21611-60	FENDER, rear	1	UR PASTEL MINERAL BLUE
5	90119-06042	BOLT, with washer	2	
6	3BN-21639-00	DAMPER 2	1	
7	95811-06012	BOLT, flange	2	
8	3BN-21685-00	BRACKET, license	1	
9	90560-08066	SPACER	2	
10	95816-08020	BOLT, flange	2	
11	95701-08500	NUT, flange	2	
12	3BN-21642-00	GUARD, flap	1	
13	90119-06194	BOLT, with washer	2	
14	99244-00020	EMBLEM, yamaha	1	UR FOR PWS1
	99241-00020	EMBLEM, yamaha	1	UR FOR Y8, PM1B

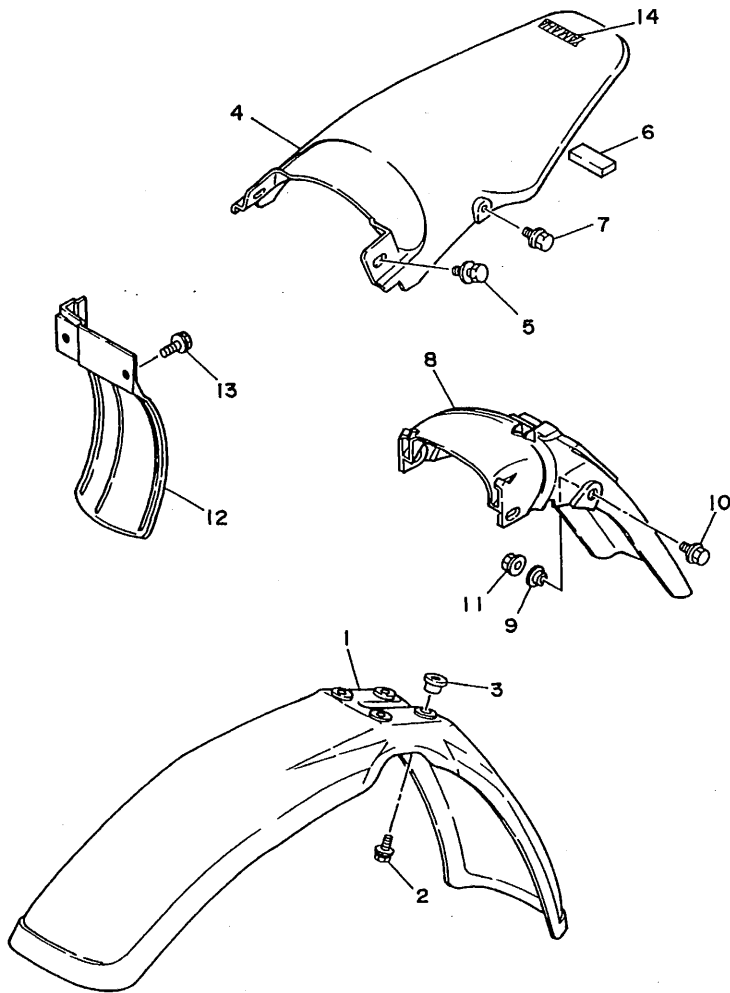

3RM3300-1180

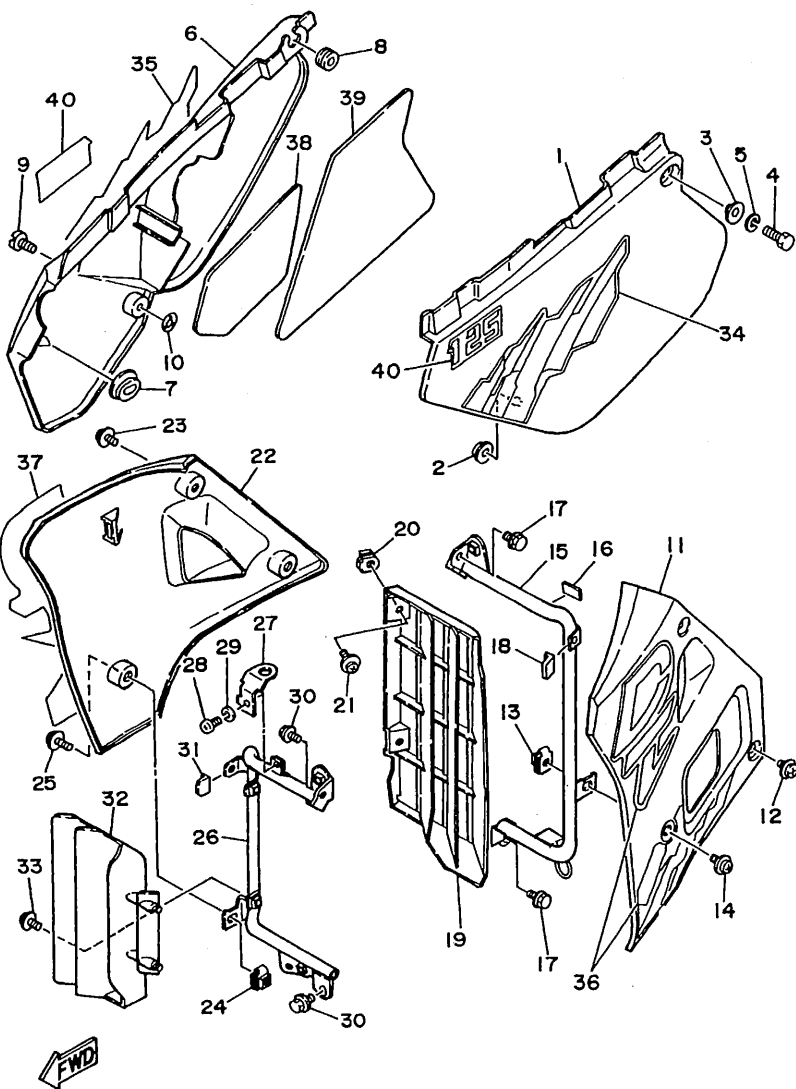

3RM5300-3190

FIG. 19 SIDE COVER

REF. NO.	PART NO.	DESCRIPTION	Q'TY	REMARKS
1	3BN-21711-40	COVER, side 1	1	UR PURPLISH WHITE SOLID 1
	3BN-21711-10	COVER, side 1	1	UR YAMAHA BLACK
	3BN-21711-60	COVER, side 1	1	UR PASTEL MINERAL BLUE
2	90480-13398	GROMMET	1	
3	90387-06500	COLLAR	1	
4	97011-06020	BOLT	1	
5	92990-06100	WASHER, spring	1	
6	3BN-21721-40-98	COVER, side 2	1	UR LOW GLOSS BLACK/ PURPLISH WHITE SOLID 1
	3BN-21721-11	COVER, side 2	1	UR YAMAHA BLACK
	3BN-21721-60-98	COVER, side 2	1	UR LOW GLOSS BLACK/ PASTEL MINERAL BLUE
7	90480-01401	GROMMET	1	
8	90480-12325	GROMMET	1	
9	90149-06194	SCREW	1	
10	4U5-2176E-00	PLATE	1	
11	3BN-2137W-40	SCOOP, air 1	1	UR PURPLISH WHITE SOLID 1
	3BN-2137W-10	SCOOP, air 1	1	UR YAMAHA BLACK
	3BN-2137W-60	SCOOP, air 1	1	UR PASTEL MINERAL BLUE
12	90159-06160	SCREW, with washer	2	UR FOR PWS1, PMIB
	90159-06165	SCREW, with washer	2	UR FOR YB
13	3BN-21791-00	NUT	1	
14	90159-05167	SCREW, with washer	1	UR FOR PWS1, PMIB
	90159-05168	SCREW, with washer	1	UR FOR YB
15	3BN-2172K-00	BRACKET 1	1	
16	3BN-21747-00	DAMPER	1	
17	91026-06010	BOLT	2	
18	90480-16185	GROMMET	1	
19	3BN-2172A-00	PANEL 1	1	
20	22W-21791-00	NUT	2	

FIG. 19 SIDE COVER

REF. NO.	PART NO.	DESCRIPTION	Q'TY	REMARKS
21	90159-05163	SCREW, with washer	2	
22	3BN-2137X-40	SCOOP, air 2	1	UR PURPLISH WHITE SOLID 1
	3BN-2137X-10	SCOOP, air 2	1	UR YAMAHA BLACK
	3BN-2137X-60	SCOOP, air 2	1	UR PASTEL MINERAL BLUE
23	90159-06160	SCREW, with washer	2	UR FOR PWS1, PMIB
	90159-06165	SCREW, with washer	2	UR FOR YB
24	3BN-21791-00	NUT	1	
25	90159-05167	SCREW, with washer	1	UR FOR PWS1, PMIB
	90159-05168	SCREW, with washer	1	UR FOR YB
26	3BN-2172L-00	BRACKET 2	1	
27	3BN-2175H-00	STAY, lock	1	
28	98506-05010	SCREW, pan head	1	
29	92906-05100	WASHER, spring	1	
30	91026-06010	BOLT	2	
31	90480-16185	GROMMET	1	
32	1LX-2172F-01	PANEL 2	1	
33	90159-05083	SCREW, with washer	2	
34	3RM-2173E-00	GRAPHIC 1	1	UR FOR PWS1
	3RM-2173E-10	GRAPHIC 1	1	UR FOR YB
	3RM-2173E-20	GRAPHIC 1	1	UR FOR PMIB
35	3RM-2173F-00	GRAPHIC 2	1	UR FOR PWS1
	3RM-2173F-10	GRAPHIC 2	1	UR FOR YB
	3RM-2173F-20	GRAPHIC 2	1	UR FOR PMIB
36	3RM-2173L-00	GRAPHIC SET 1	1	UR FOR PWS1
	3RM-2173L-10	GRAPHIC SET 1	1	UR FOR YB
	3RM-2173L-20	GRAPHIC SET 1	1	UR FOR PMIB
37	3RM-2174L-00	GRAPHIC SET 2	1	UR FOR PWS1
	3RM-2174L-10	GRAPHIC SET 2	1	UR FOR YB

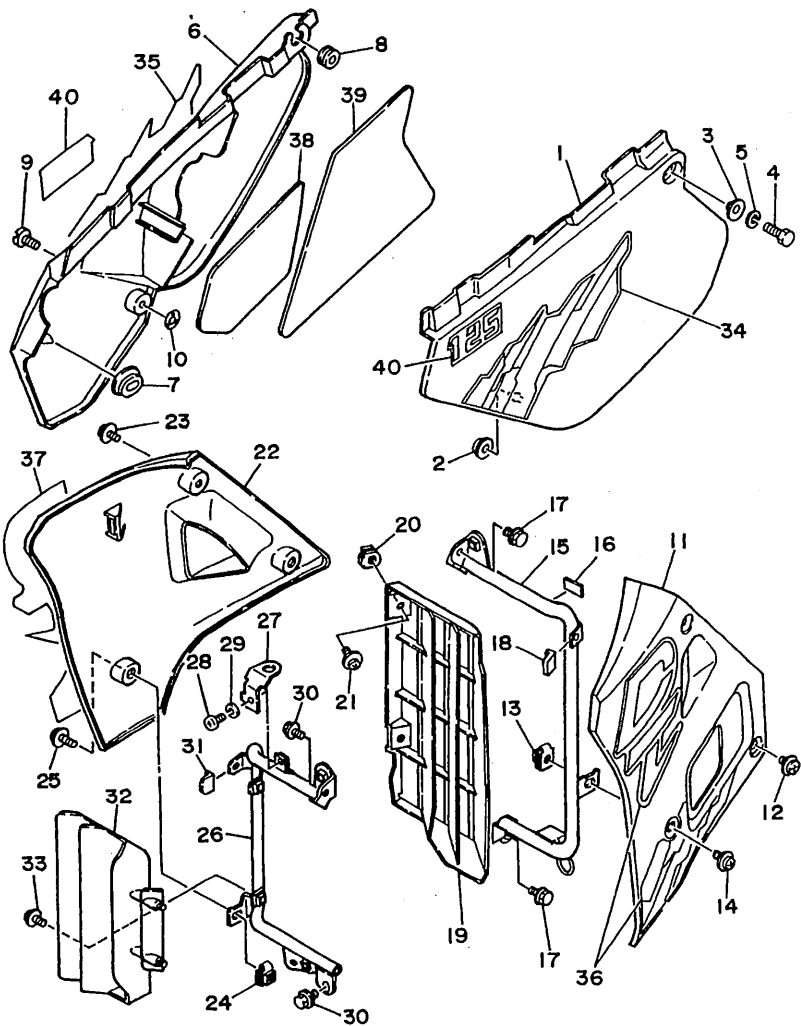

3RM5300-3190

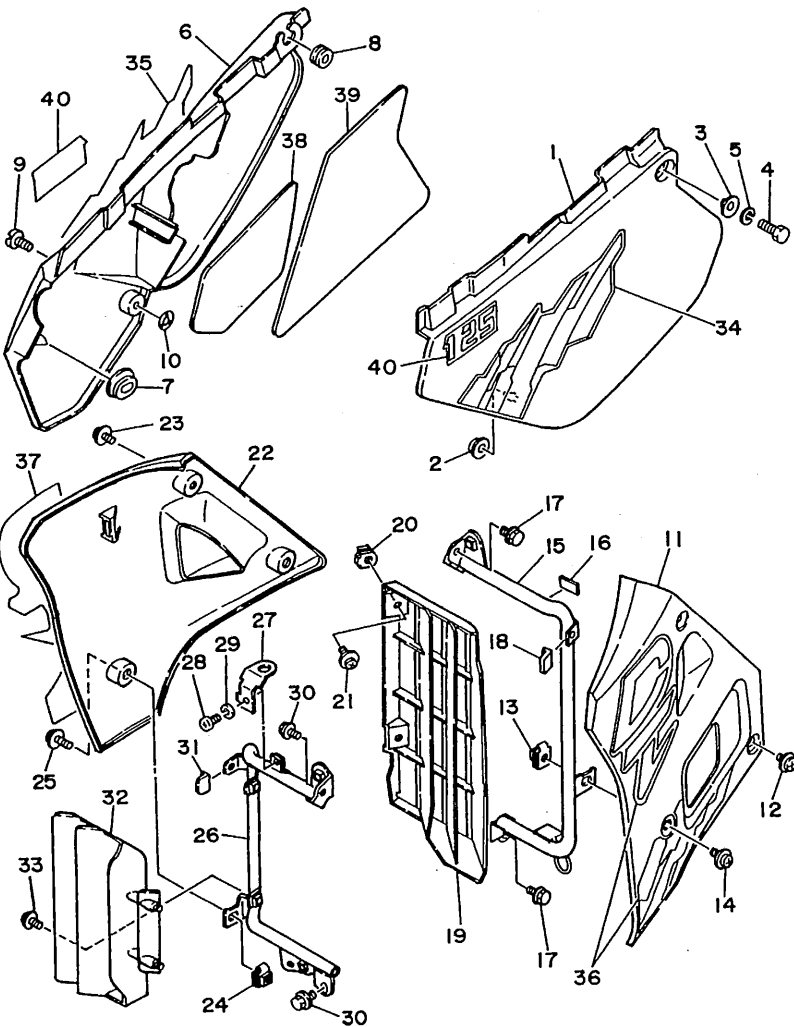

3RM5300-3190

FIG. 19 SIDE COVER

REF. NO.	PART NO.	DESCRIPTION	Q'TY	REMARKS
37	3RM-2174L-20	GRAPHIC SET 2	1	UR FOR PMIB
38	3BN-2174A-00	INSULATOR, side cover	1	
39	3BN-2174T-00	INSULATOR, side cover 2	1	
40	3RM-21781-00	EMBLEM 1	2	UR FOR PWS1
	3RM-21781-10	EMBLEM 1	2	UR FOR YB
	3RM-21781-20	EMBLEM 1	2	UR FOR PMIB

FIG. 20 OIL TANK

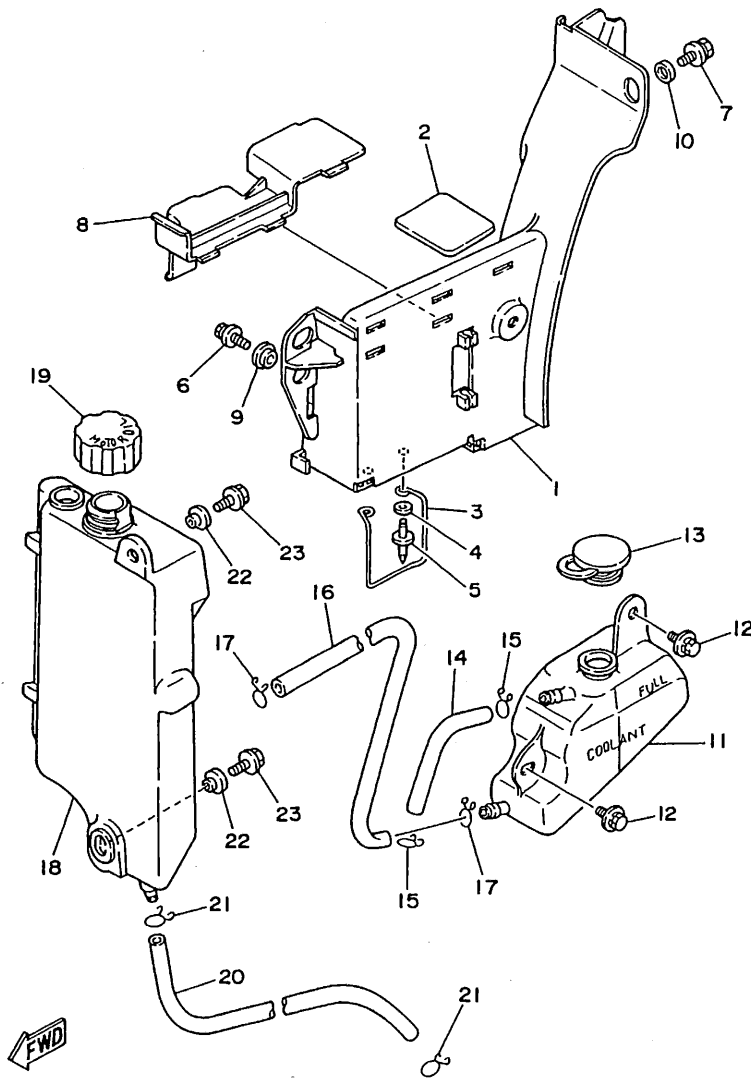

REF. NO.	PART NO.	DESCRIPTION	Q'TY	REMARKS
1	3BN-2177A-00	BOX	1	
2	3BN-21638-00	DAMPER 1	1	
3	3ET-21339-00	GUIDE, wire	1	
4	90201-044A2	WASHER, plate	2	
5	90267-40029	RIVET, blind	2	
6	90119-06056	BOLT, with washer	1	
7	90119-06118	BOLT, with washer	1	
8	3BN-2176E-00	PLATE	1	
9	90560-08066	SPACER	1	
10	90387-082J1	COLLAR	1	
11	3BN-21871-00	TANK, recovery	1	
12	90119-06056	BOLT, with washer	2	
13	10V-21875-00	CAP	1	
14	90445-09073	HOSE	1	
15	90467-08003	CLIP	2	
16	3BN-21877-00	PIPE, overflow	1	
17	90467-10008	CLIP	2	
18	3BN-21751-00	TANK, oil	1	
19	3BN-21770-00	OIL TANK CAP ASSY	1	
20	3BN-13416-00	PIPE, oil 1	1	
21	90467-08003	CLIP	2	
22	90387-06681	COLLAR	2	
23	91001-06016	BOLT, flange	2	

3RN2361-0200

C14

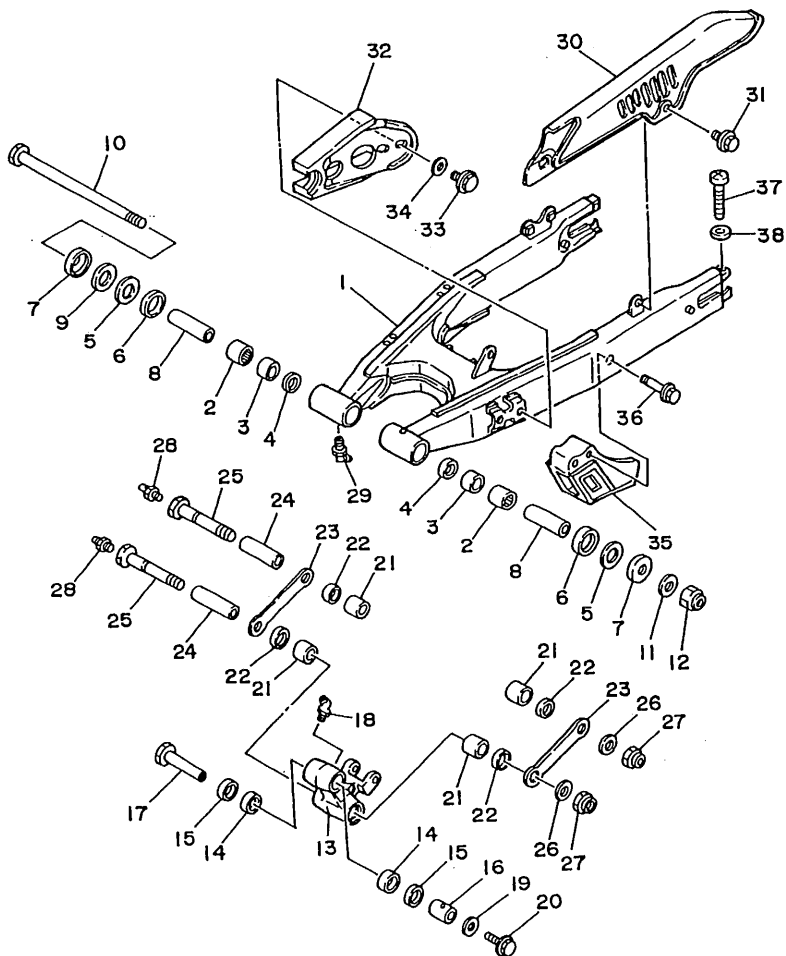

FIG. 21 REAR ARM

REF. NO.	PART NO.	DESCRIPTION	Q'TY	REMARKS
1	3BN-22110-01-35	REAR ARM COMP.	1	SILVER
2	93317-32231	BEARING, cylindrical	2	
3	90380-22111	BUSH, solid	2	
4	93106-22019	OIL SEAL (DC 22-28-8)	2	
5	90201-254H8	WASHER, plate	2	
6	93108-35004	OIL SEAL (35-41-8)	2	
7	30X-2219X-00	COVER	2	
8	90380-16077	BUSH, solid	2	
9	90201-251F6	WASHER, plate	2	UN
10	3R4-22141-00	SHAFT, pivot	1	
11	90201-164H4	WASHER, plate	1	
12	90185-16127	NUT, self-locking	1	
13	3BN-2217A-00	ARM, relay	1	
14	93315-32044	BEARING (YT2015)	2	IKO
15	93109-20029	OIL SEAL	2	
16	90387-164U7	COLLAR	1	
17	90402-10005	NUT, union	1	
18	93700-06005	NIPPLE, grease	1	
19	90201-106F2	WASHER, plate	1	
20	91011-10016	BOLT, flange	1	
21	90386-20120	BUSH	4	
22	93109-20029	OIL SEAL	4	
23	3BN-2217F-00	ROD, connecting 1	2	
24	90387-164U8	COLLAR	2	
25	90401-14136	BOLT, union	2	
26	90201-160F6	WASHER, plate	2	
27	90185-14070	NUT, self-locking	2	
28	93700-06004	NIPPLE, grease	2	



3MB1300-9220



FIG. 21 REAR ARM

REF. NO.	PART NO.	DESCRIPTION	Q'TY	REMARKS
29	93700-06005	NIPPLE, grease	2	
30	3TB-22311-00	CASE, chain	1	
31	90119-06117	BOLT, with washer	2	
32	1LN-22151-00	SEAL, guard	1	
33	90119-06117	BOLT, with washer	2	
34	90209-06223	WASHER	2	
35	34X-22153-00	GUARD, chain	1	
36	95801-06050	BOLT, flange	2	
37	92011-06060	SCREW	2	
38	92901-06600	WASHER, plate	2	

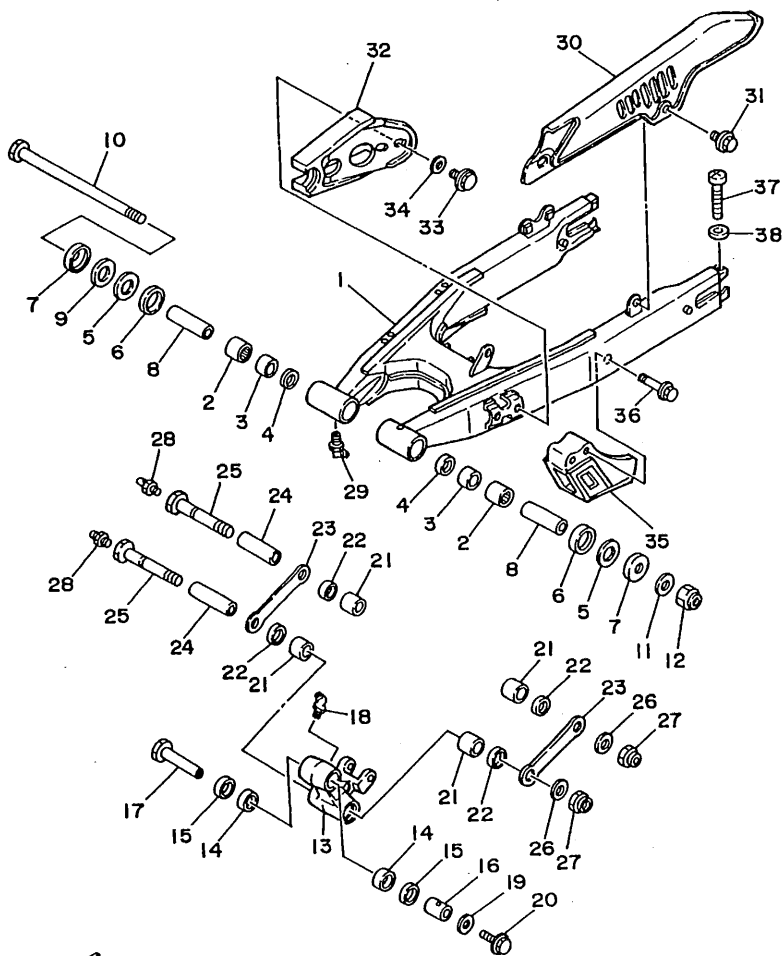

3MB1300-9220

FIG. 22 REAR SUSPENSION

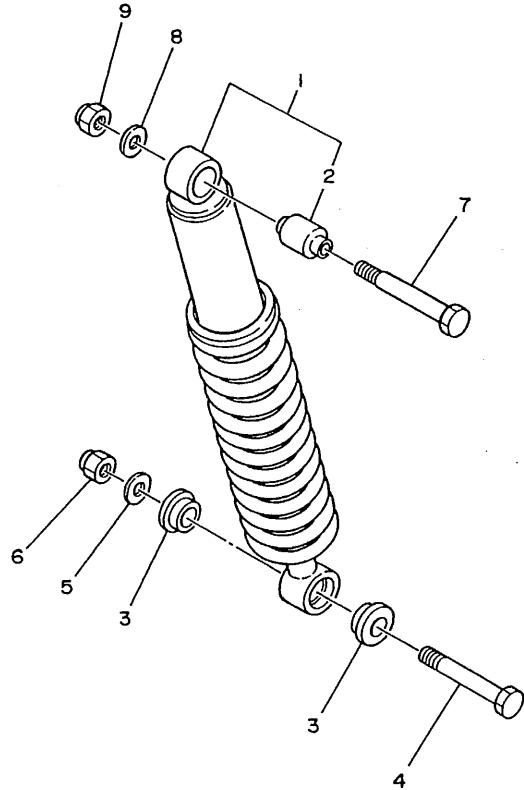

REF. NO.	PART NO.	DESCRIPTION	Q'TY	REMARKS
1	3RM-22210-10-P0	SHOCK ABSORBER ASSY, rear	1	VIVID MAGENTA SOLID 2
2	1YW-22216-00	.BUSH, rear shock absorber	1	
3	90387-126H8	COLLAR	2	
4	90109-10704	BOLT	1	
5	90201-100E9	WASHER, plate	1	
6	90185-10120	NUT, self-locking	1	
7	90109-100E2	BOLT	1	
8	90201-100E9	WASHER, plate	1	
9	90185-10120	NUT, self-locking	1	



3BN300-8220

D3

FIG. 23 STEERING

REF. NO.	PART NO.	DESCRIPTION	Q'TY	REMARKS
1	93332-00008	BEARING	1	
2	22F-23411-01	RACE, ball 1	1	
3	22F-23412-01	RACE, ball 2	1	
4	93503-16010	BALL	22	
5	10V-23416-01	COVER, ball race 2	1	
6	90179-25033	NUT	1	
7	3BN-23435-00-35	CROWN, handle	1	SILVER
8	90176-22050	NUT	1	
9	91316-08035	BOLT	1	
10	95026-08040	BOLT, flange	4	
11	1E6-23441-10-35	HOLDER, handle upper	2	SILVER
12	91026-08035	BOLT	4	
13	3BN-23174-00'	STAY, headlight	1	
14	91026-06012	BOLT	1	
15	30X-23445-00	DAMPER	1	
16	*	BODY & KEY, steering lock	1	LM
17	134-23484-10	CAP, handle lock	1	
18	90269-04003	RIVET	1	
19	90208-04029	WASHER, conical spring	1	
20	26A-23318-00	HOLDER, cable 1	1	
21	98503-05025	SCREW, pan head	1	
22	92901-05600	WASHER, plate	1	
23	95303-05600	NUT	1	
24	90465-14242	CLAMP	2	
25	91316-06012	BOLT	2	
26	3BN-23317-00	HOLDER, cable	1	

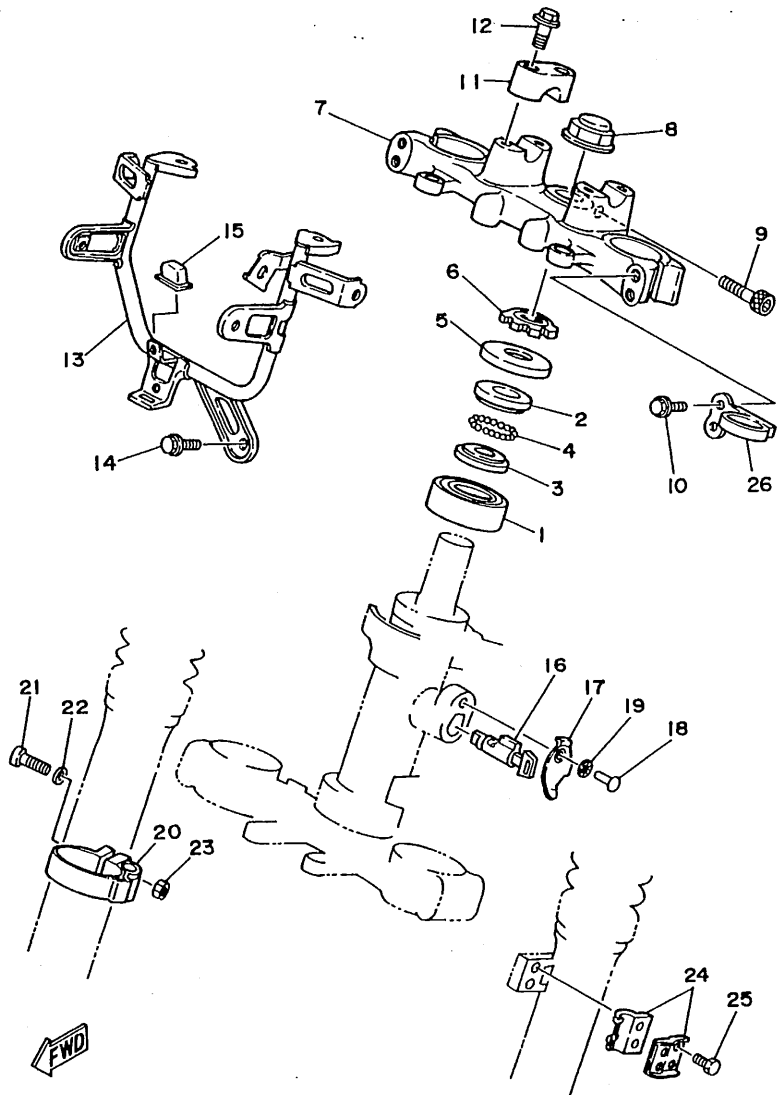

3MB1300-9240

D4

FIG. 24 FRONT FORK

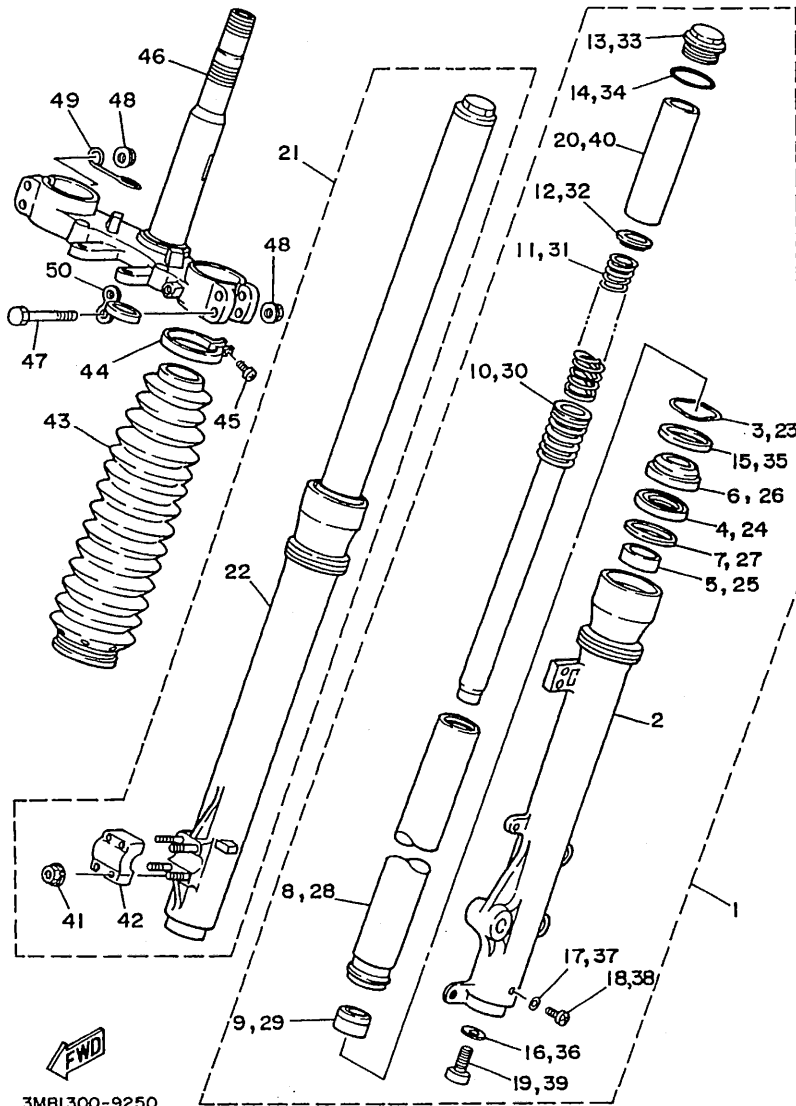

3MB1300-9250

REF. NO.	PART NO.	DESCRIPTION	Q'TY	REMARKS
1	3BN-23102-01	FRONT FORK ASSY (L.H)	1	
2	3BN-23126-00	.TUBE, outer 1	1	
3	26H-23156-00	.CLIP, oil seal	1	
4	3BN-23145-00	.OIL SEAL	1	
5	3BN-23125-00	.METAL, slide 1	1	
6	43F-23144-10	.SEAL, dust	1	
7	36Y-23146-10	.WASHER, oil seal	1	
8	3BN-23110-00	.INNER TUBE COMP.1	1	
9	4V4-23173-L0	.SPINDLE, taper	1	
10	3BN-23170-00	.CYLINDER COMP., front fork	1	
11	3BN-23141-01	.SPRING, front fork	1	
12	43F-23142-10	.SEAT, spring upper	1	
13	3EN-23111-50	.BOLT, cap	1	
14	43F-23188-10	.O-RING	1	
15	3BN-23146-00	.WASHER, oil seal	1	
16	4V4-23158-L0	.GASKET	1	
17	122-23129-00	.GASKET, drain plug	1	
18	4H7-23119-00	.PLUG, drain	1	
19	4V4-23181-L0	.BOLT, hexagon socket head	1	
20	3BN-23118-01	.SPACER	1	
21	3BN-23103-01	FRONT FORK ASSY (R.H)	1	
22	3BN-23136-00	.TUBE, outer 2	1	
23	26H-23156-00	.CLIP, oil seal	1	
24	3BN-23145-00	.OIL SEAL	1	
25	3BN-23125-00	.METAL, slide 1	1	
26	43F-23144-10	.SEAL, dust	1	
27	36Y-23146-10	.WASHER, oil seal	1	
28	3BN-23110-00	.INNER TUBE COMP.1	1	

D5

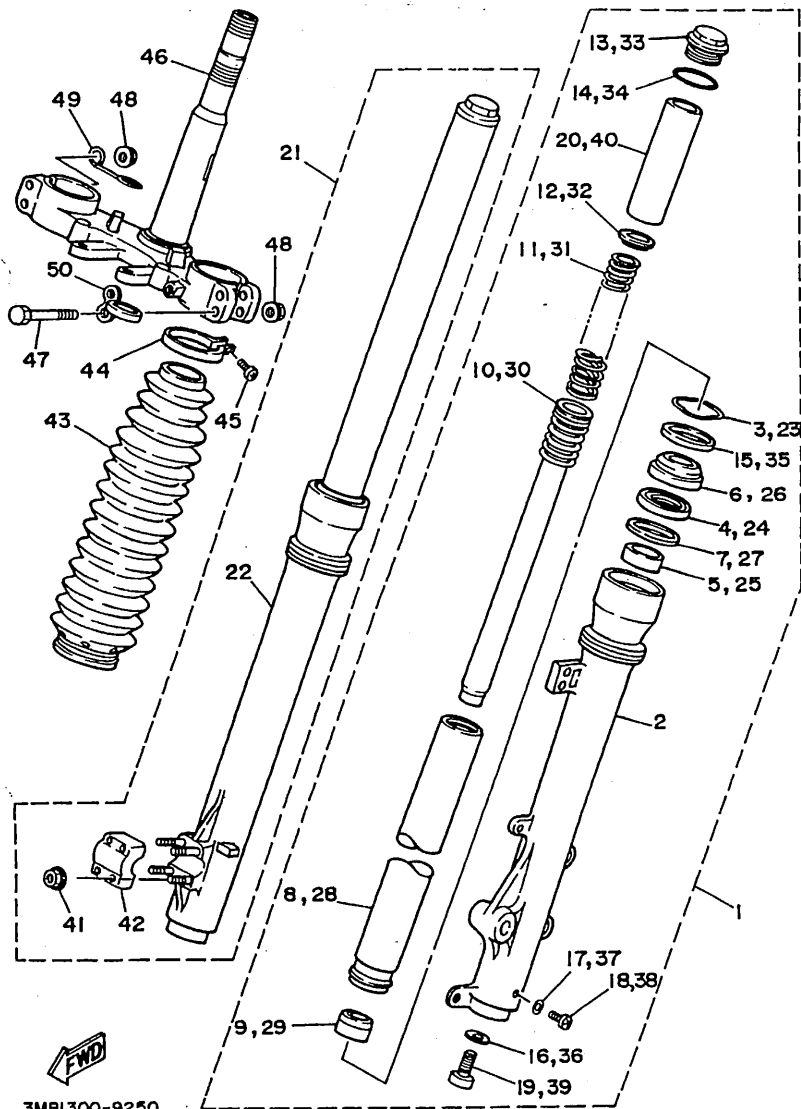
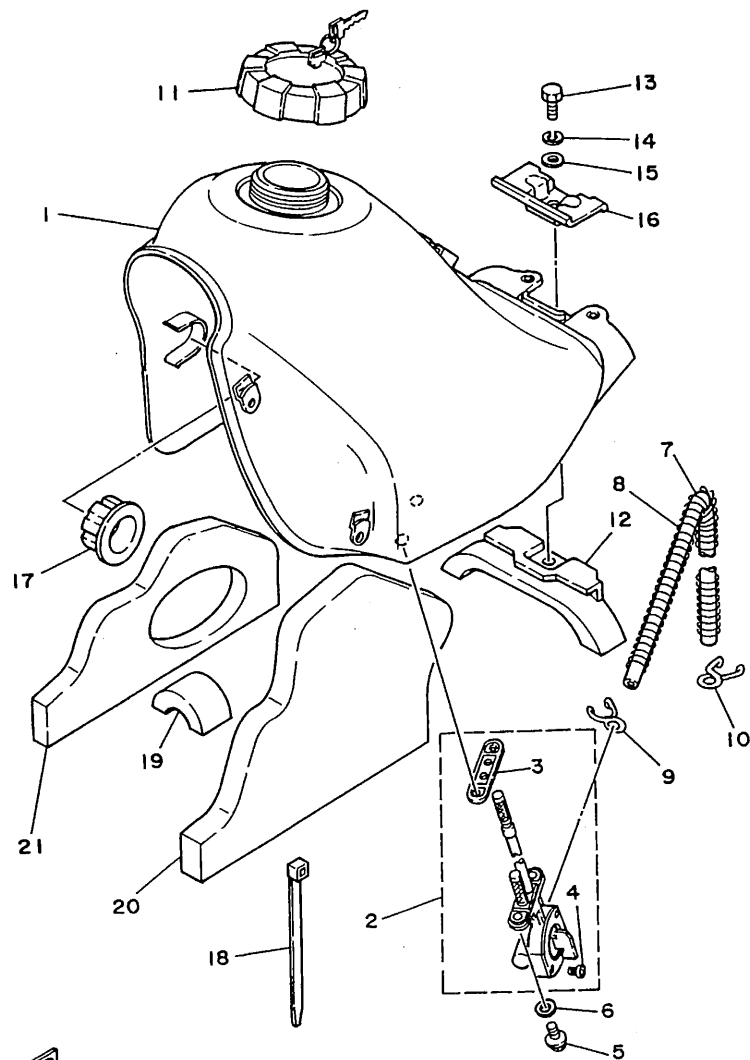

FIG. 24 FRONT FORK

REF. NO.	PART NO.	DESCRIPTION	Q'TY	REMARKS
29	4V4-23173-L0	.SPINDLE, taper	1	
30	3BN-23170-00	.CYLINDER COMP., front fork	1	
31	3BN-23141-01	.SPRING, front fork	1	
32	43F-23142-10	.SEAT, spring upper	1	
33	3EN-23111-50	.BOLT, cap	1	
34	43F-23188-10	.O-RING	1	
35	3BN-23146-00	.WASHER, oil seal	1	
36	4V4-23158-L0	.GASKET	1	
37	122-23129-00	.GASKET, drain plug	1	
38	4H7-23119-00	.PLUG, drain	1	
39	4V4-23181-L0	.BOLT, hexagon socket head	1	
40	3BN-23118-01	.SPACER	1	
41	2KF-23127-01	.NUT, outer tube	4	
42	4V2-23167-L0	.HOLDER, axle	1	
43	3BN-23191-30	BOOT	2	UR VIVID MAGENTA SOLID 2
	3TB-23191-11	BOOT	2	UR BLACK
	3BJ-23191-01	BOOT	2	UR DEEP VIOLET SOLID 1
44	43M-23192-L0	BAND	2	
45	98506-04018	SCREW, pan head	2	
46	3BN-23340-00	UNDER BRACKET COMP.	1	
47	95811-08055	BOLT, flange	4	
48	95701-08500	NUT, flange	4	
49	4V5-23389-00	GUIDE, cable	1	
50	3R4-23317-00	HOLDER, cable	1	

FIG. 25 FUEL TANK



REF. NO.	PART NO.	DESCRIPTION	Q'TY	REMARKS
1	3BN-24110-00-P0	FUEL TANK COMP.	1	UR PURPLISH WHITE SOLID 1
	3BN-24110-00-33	FUEL TANK COMP.	1	UR YAMAHA BLACK
	3BN-24110-00-T7	FUEL TANK COMP.	1	UR PASTEL MINERAL BLUE
2	3BN-24500-00	FUEL COCK ASSY 1	1	
3	4X8-24512-00	.0-RING	1	
4	98503-03008	.SCREW, pan head	2	
5	90149-06011	SCREW	2	
6	90202-05193	WASHER, plate	2	
7	3ET-24311-00	PIPE, fuel 1	1	
8	90501-08410	SPRING, compression	1	
9	90467-08003	CLIP	1	
10	90467-10008	CLIP	1	
11	48Y-24602-00	CAP ASSY	1	
12	3BN-24182-00	DAMPER, locating 2	1	
13	97313-06016	BOLT	1	
14	92990-06100	WASHER, spring	1	
15	92901-06600	WASHER, plate	1	
16	34X-24186-01	WASHER, special	1	
17	26H-24181-00	DAMPER, locating 1	2	
18	90464-13080	CLAMP	1	
19	5X2-24184-00	DAMPER, locating 4	1	
20	3BN-2414H-00	DAMPER, plate 1	1	
21	3BN-2414J-00	DAMPER, plate 2	1	



3MBI300-9260

D7

FIG. 26 SEAT

REF. NO.	PART NO.	DESCRIPTION	Q'TY	REMARKS
1	3ET-24730-A0	DOUBLE SEAT ASSY	1	UR VIVID MAGENTA SOLID 2
	3ET-24730-E0	DOUBLE SEAT ASSY	1	UR DEEP VIOLET SOLID 1
	3ET-24730-D0	DOUBLE SEAT ASSY	1	UR GREENISH BLUE SOLID 1
2	3BN-24731-50	.COVER, seat	1	UR VIVID MAGENTA SOLID 2
	3BN-24731-80	.COVER, seat	1	UR DEEP VIOLET SOLID 1
	3BN-24731-70	.COVER, seat	1	UR GREENISH BLUE SOLID 1
3	509-24724-00	.DAMPER, seat	2	
4	90119-06043	BOLT, with washer	2	
5	3BN-24830-00	SUB CARRIER ASSY	1	

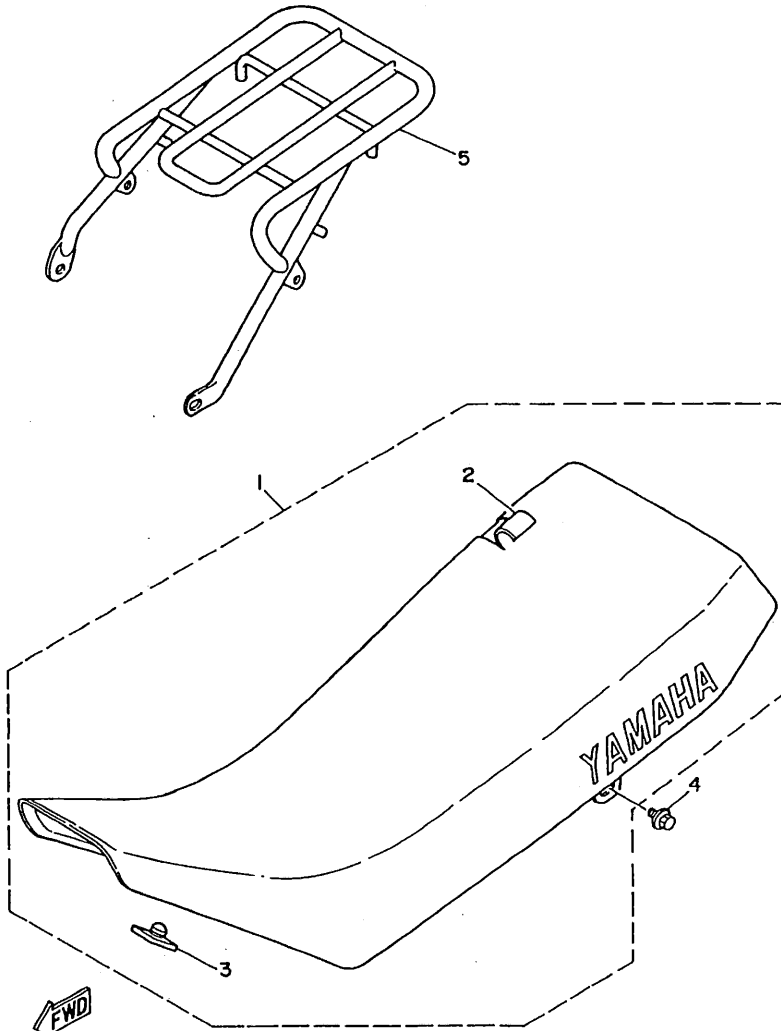

3RMI300-9260

D8

FIG. 27 FRONT WHEEL

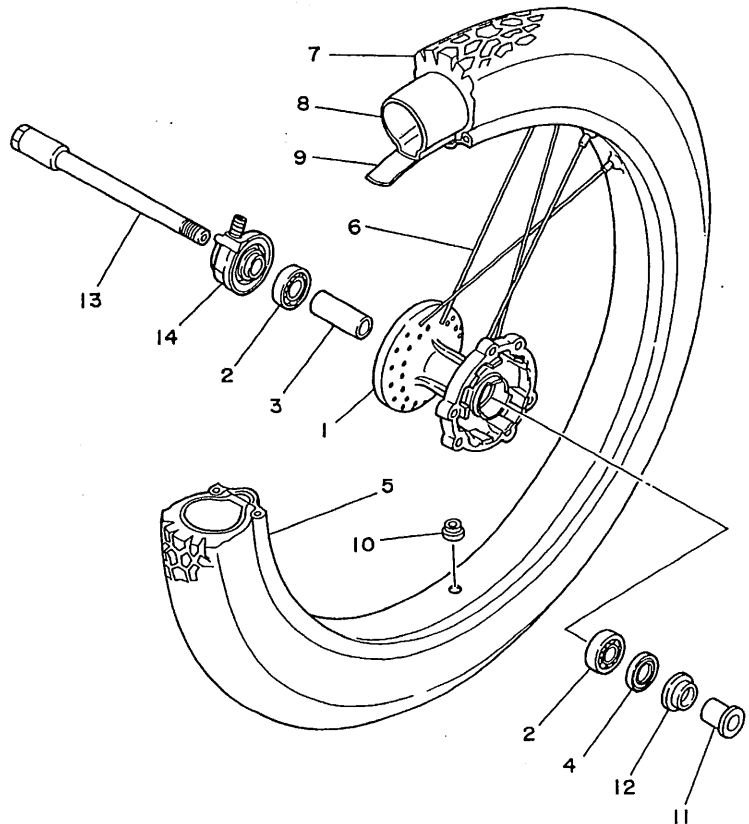

REF. NO.	PART NO.	DESCRIPTION	Q'TY	REMARKS
1	34X-25111-02-35	HUB, front	1	SILVER
2	93306-20209	BEARING (B6202)	2	
3	90560-15290	SPACER	1	
4	93102-20281	OIL SEAL (SD 20-35-5)	1	
5	94416-21392	RIM (1.60-21)	1	
6	34Y-25104-00	SPOKE SET, front	1	
7	94127-216T2	TIRE (2.75-21)	1	UR YOKOHAMA
	94127-214F2	TIRE (2.75-21)	1	UR BRIDGESTONE
8	94225-21186	TUBE (2.50-21)	1	UR YOKOHAMA
	94227-21123	TUBE (2.75-21)	1	UR BRIDGESTONE
9	94325-21117	BAND, rim (2.50-21)	1	UR YOKOHAMA
	94330-21084	BAND, rim (3.00-21)	1	UR BRIDGESTONE
10	90338-09130	PLUG	1	
11	90387-15600	COLLAR	1	
12	322-25118-00	COVER, hub dust	1	
13	55U-25181-01	AXLE, wheel	1	
14	1W2-25190-01	GEAR UNIT ASSY	1	



3BN300-8270

D9



FIG. 28 FRONT BRAKE CALIPER

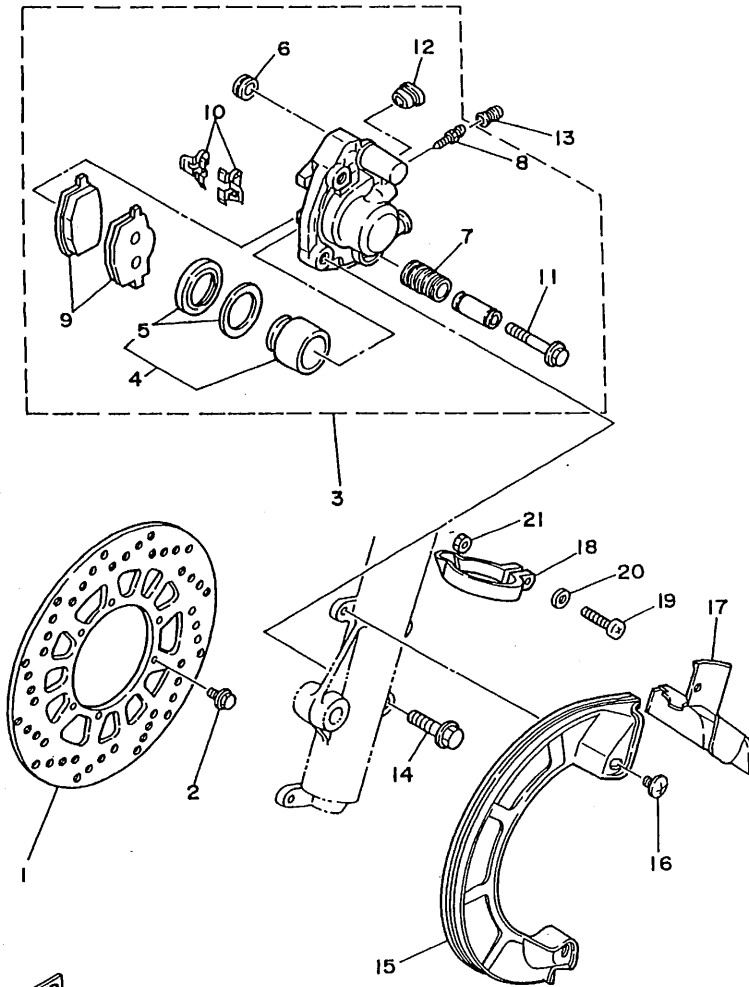

REF. NO.	PART NO.	DESCRIPTION	Q'TY	REMARKS
1	3BN-2582T-00	DISC, brake (LEFT)	1	
2	90109-06757	BOLT	6	
3	3BN-2580T-10	CALIPER ASSY (LEFT)	1	
4	34X-W0057-00	.PISTON ASSY, caliper	1	
5	34X-W0047-00	..CALIPER SEAL KIT	1	
6	5R2-25937-00	.BOOT 2	1	
7	34X-25937-00	.BOOT 2	1	
8	47X-25824-00	.SCREW, breed	1	
9	3BN-W0045-01	.BRAKE PAD KIT	1	
10	34X-25919-00	.SUPPORT, pad	2	
11	34X-25926-00	.BOLT	1	
12	34X-25845-00	.CAP, indicator	1	
13	51L-25825-00	CAP	1	
14	90105-10308	BOLT, washer based	2	
15	38N-25715-40	COVER 1	1	UR VIVID MAGENTA SOLID 2
	55U-25715-00	COVER 1	1	UR BLACK
16	90149-06194	SCREW	2	
17	38N-25716-50	COVER 2	1	UR VIVID MAGENTA SOLID 2
	55U-25716-00	COVER 2	1	UR BLACK
18	3ET-25719-00	BAND	1	
19	98501-05016	SCREW, pan head	1	
20	92901-05600	WASHER, plate	1	
21	95303-05600	NUT	1	



3E010-8270

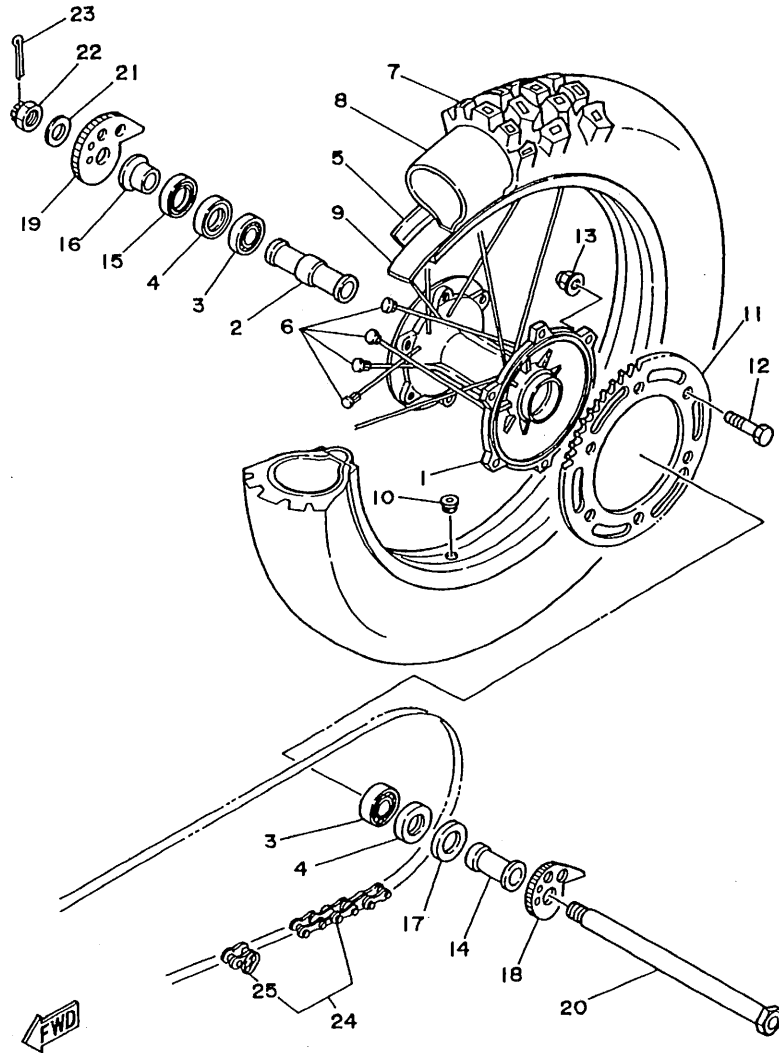

3MB1300-9300

FIG. 29 REAR WHEEL

REF. NO.	PART NO.	DESCRIPTION	Q'TY	REMARKS
1	3BN-25311-01-35	HUB, rear	1	SILVER
2	90560-20340	SPACER	1	
3	93306-00438	BEARING	2	
4	93106-28023	OIL SEAL	2	
5	94418-18466	RIM (1.85-18)	1	
6	3BN-25304-00	SPOKE SET, rear	1	
7	94141-186T3	TIRE (4.10-18)	1	UR YOKOHAMA
	94141-186T1	TIRE (4.10-18)	1	UR BRIDGESTONE
8	94235-18085	TUBE (3.50-18)	1	UR YOKOHAMA
	94241-18153	TUBE (4.10-18)	1	UR BRIDGESTONE
9	94340-18086	BAND, rim (4.00-18)	1	UR BRIDGESTONE
	94345-18081	BAND, rim (4.50-18)	1	UR INOUE
10	90338-09130	PLUG	1	
11	3MB-25457-20	SPROCKET, driven (57T)	1	
12	90109-08618	BOLT	6	
13	90185-08146	NUT, self-locking	6	
14	90387-204U9	COLLAR	1	
15	4V4-25367-00	COVER, hub dust	1	
16	90387-202U8	COLLAR	1	
17	4V4-25367-00	COVER, hub dust	1	
18	3BN-25388-00	PULLER, chain 1	1	
19	3BN-25389-00	PULLER, chain 2	1	
20	3BN-25381-00	AXLE, wheel	1	
21	90201-204M9	WASHER, plate	1	
22	95301-18900	NUT	1	
23	91401-30030	PIN, cotter	1	
24	94581-33134	CHAIN	1	
25	94681-33011	JOINT, chain	1	

FIG. 30 REAR BRAKE CALIPER

REF. NO.	PART NO.	DESCRIPTION	Q'TY	REMARKS
1	3BN-2582W-00	DISC, rear brake 2	1	
2	90149-06270	SCREW	6	
3	3BN-2580W-10	CALIPER ASSY, rear 2	1	
4	2VN-W0057-00	.PISTON ASSY, caliper	1	
5	2NA-W0047-00	..CALIPER SEAL KIT	1	
6	34X-25937-00	.BOOT 2	1	
7	47X-25824-00	.SCREW, breed	1	
8	34X-25845-00	.CAP, indicator	1	
9	2KF-25919-00	.SUPPORT, pad	2	
10	5R2-25937-00	.BOOT 2	1	
11	34X-W0046-02	.BRAKE PAD KIT, rear	1	
12	2GV-25926-00	.BOLT	1	
13	2KF-25827-00	.SHIM, caliper	1	
14	2KF-25828-00	.SHIM, caliper	1	
15	51L-25825-00	CAP	1	
16	2KF-27491-00	PROTECTOR	1	
17	95801-06010	BOLT, flange	2	

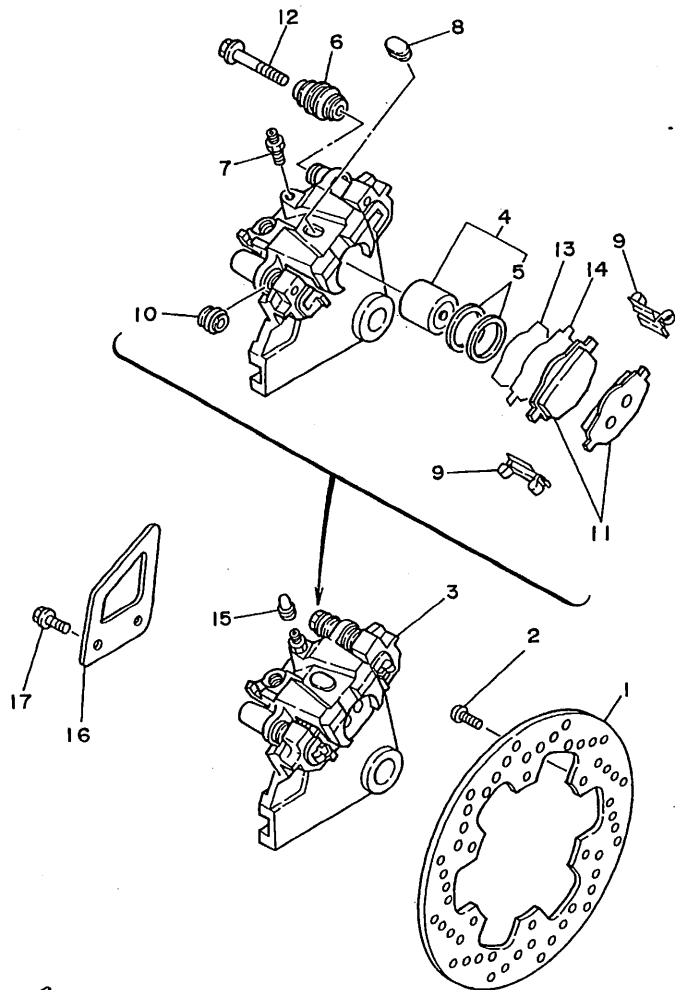

3BN300-8300

FIG. 31 STEERING HANDLE. CABLE

REF. NO.	PART NO.	DESCRIPTION	Q'TY	REMARKS
1	2JX-26111-00	HANDLEBAR	1	
2	55V-26280-00	REAR VIEW MIRROR ASSY (LEFT)	1	
3	55V-26290-00	REAR VIEW MIRROR ASSY (RIGHT)	1	
4	434-26243-00	TUBE, throttle guide	1	
5	33G-26242-00	GRIP (R.H)	1	
6	1M1-26249-01	RING, leaf	1	
7	33G-26241-00	GRIP	1	
8	3ET-26301-00	THROTTLE CABLE ASSY	1	
9	3BN-26335-00	CABLE, clutch	1	
10	90123-08046	BOLT	1	
11	90179-08148	NUT	1	
12	3BN-26141-20	GUARD, brush 1	1	UR PURPLISH WHITE SOLID 1
	2KF-26141-00	GUARD, brush 1	1	UR YAMAHA BLACK
13	3BN-26142-20	GUARD, brush 2	1	UR PURPLISH WHITE SOLID 1
	2YK-26142-10	GUARD, brush 2	1	UR YAMAHA BLACK
14	1E6-26342-00	BOOT, cable	1	
15	98501-06035	SCREW, pan head	1	
16	92901-06600	WASHER, plate	1	
17	92901-06600	WASHER, plate	1	
18	95303-06700	NUT	1	
19	90387-06500	COLLAR	1	

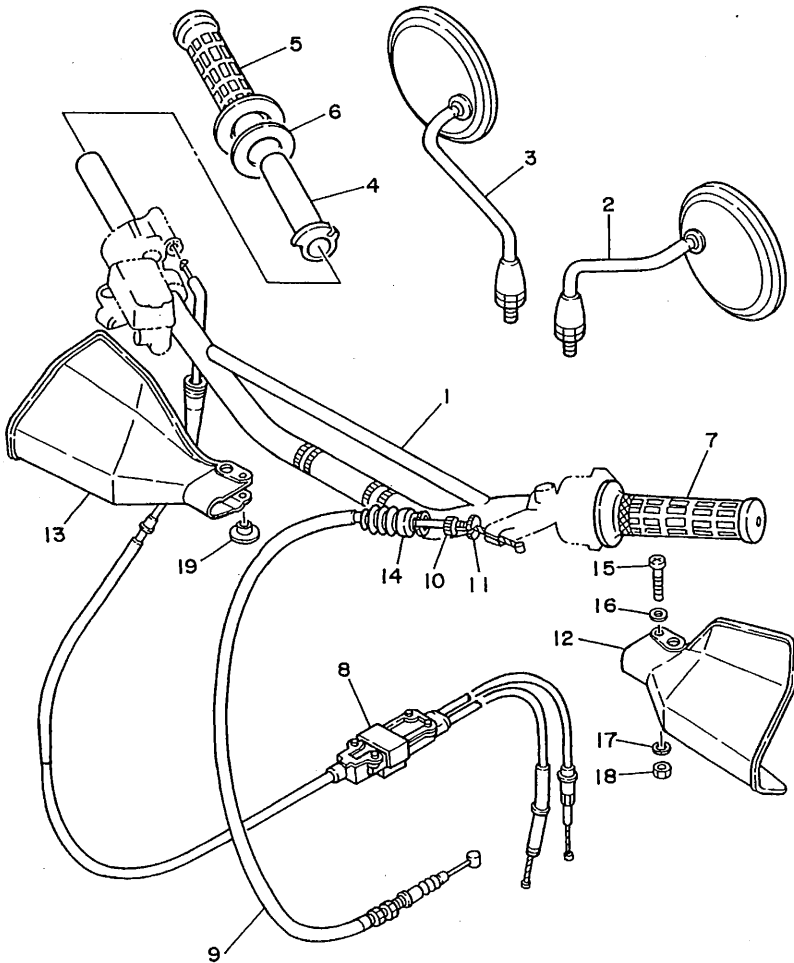

3BN300-8310

D13

FIG. 32 FRONT MASTER CYLINDER

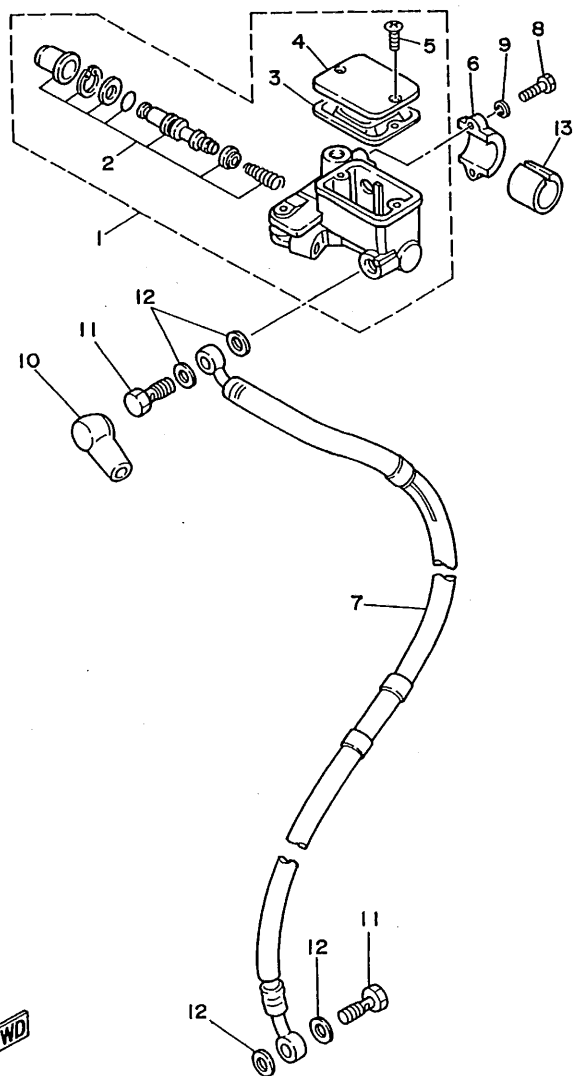

REF. NO.	PART NO.	DESCRIPTION	Q'TY	REMARKS
1	2KF-25850-00	MASTER CYLINDER ASSY	1	
2	59X-W0041-00	.CYLINDER KIT, master	1	
3	55U-25854-00	.DIAPHRAGM, reservoir	1	
4	2KF-25852-01	.CAP, reservoir	1	
5	98706-04012	.SCREW, flat head	2	
6	56A-25867-00	BRACKET, master cylinder	1	
7	3BN-25872-01	HOSE, brake 1	1	
8	97016-06025	BOLT	2	
9	92906-06100	WASHER, spring	2	
10	4L0-25862-00	BOOT, master cylinder	1	
11	90401-10034	BOLT, union	2	
12	90201-10118	WASHER, plate	4	
13	90387-225N2	COLLAR	1	

FWD

3BN300-8320

D14

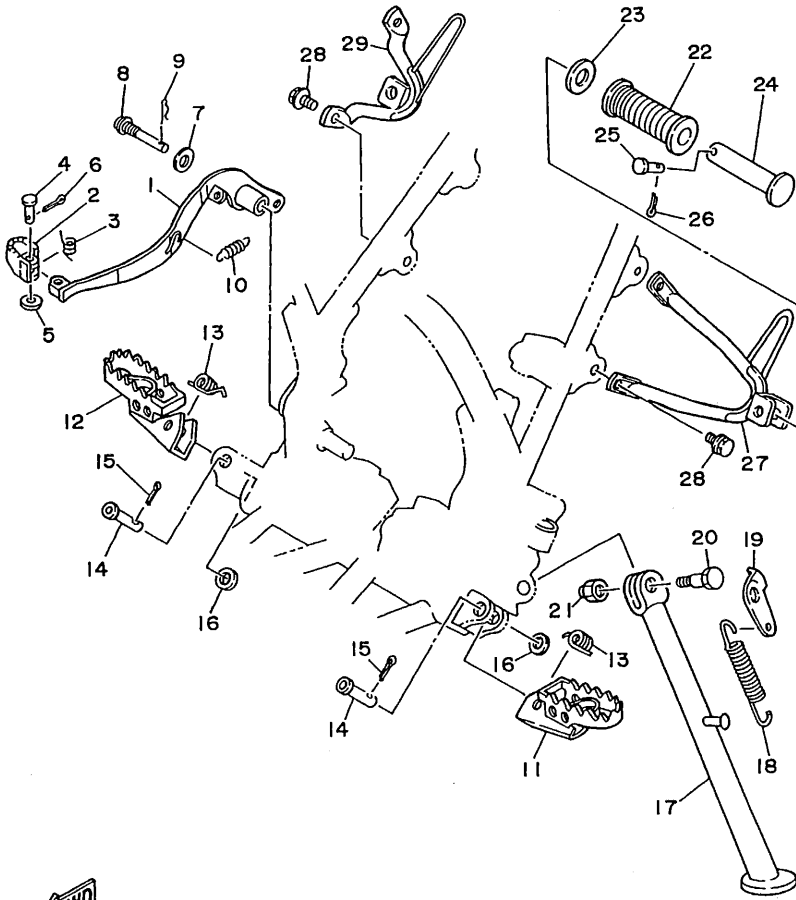

3BN300-8330

FIG. 33 STAND, FOOTREST

REF. NO.	PART NO.	DESCRIPTION	Q'TY	REMARKS
1	3BN-27211-00	PEDAL, brake	1	
2	55V-27242-00	PEDAL, brake	1	
3	90508-14352	SPRING, torsion	1	
4	91701-06022	PIN, clevis	1	
5	92901-06600	WASHER, plate	1	
6	91401-20015	PIN, cotter	1	
7	90201-081A6	WASHER, plate	1	
8	90149-08269	SCREW	1	
9	90468-10050	CLIP	1	
10	90506-18305	SPRING, tension	1	
11	2VN-27411-00	FOOTREST 1	1	
12	2VN-27421-00	FOOTREST 2	1	
13	90508-20583	SPRING, torsion	2	
14	90240-10101	PIN, clevis	2	
15	91401-25020	PIN, cotter	2	
16	90201-10119	WASHER, plate	2	
17	3BN-27311-02	STAND, side	1	
18	90506-29276	SPRING, tension	1	
19	42U-27315-01	LINK, side stand	1	
20	90109-10474	BOLT	1	
21	90185-10037	NUT, self-locking	1	
22	120-27433-00	COVER, rear footrest	2	
23	90201-20279	WASHER, plate	2	
24	120-27431-00	FOOTREST, rear 1	2	
25	90240-06009	PIN, clevis	2	
26	91401-16015	PIN, cotter	2	
27	3BN-27432-00-33	BRACKET 1	1	YAMAHA BLACK
28	90109-08789	BOLT	4	

D15

FIG. 33 STAND, FOOTREST

REF. NO.	PART NO.	DESCRIPTION	Q'TY	REMARKS
29	3BN-27442-00-33	BRACKET 2	1	YAMAHA BLACK

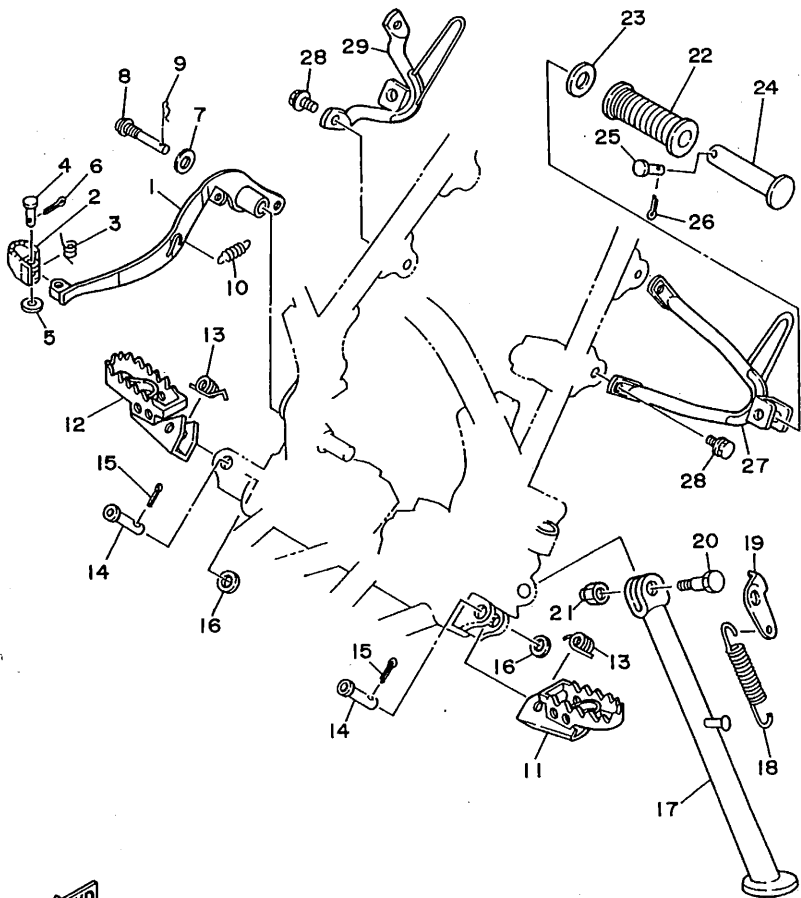

3BN300-8330

E2

FIG. 34 REAR MASTER CYLINDER

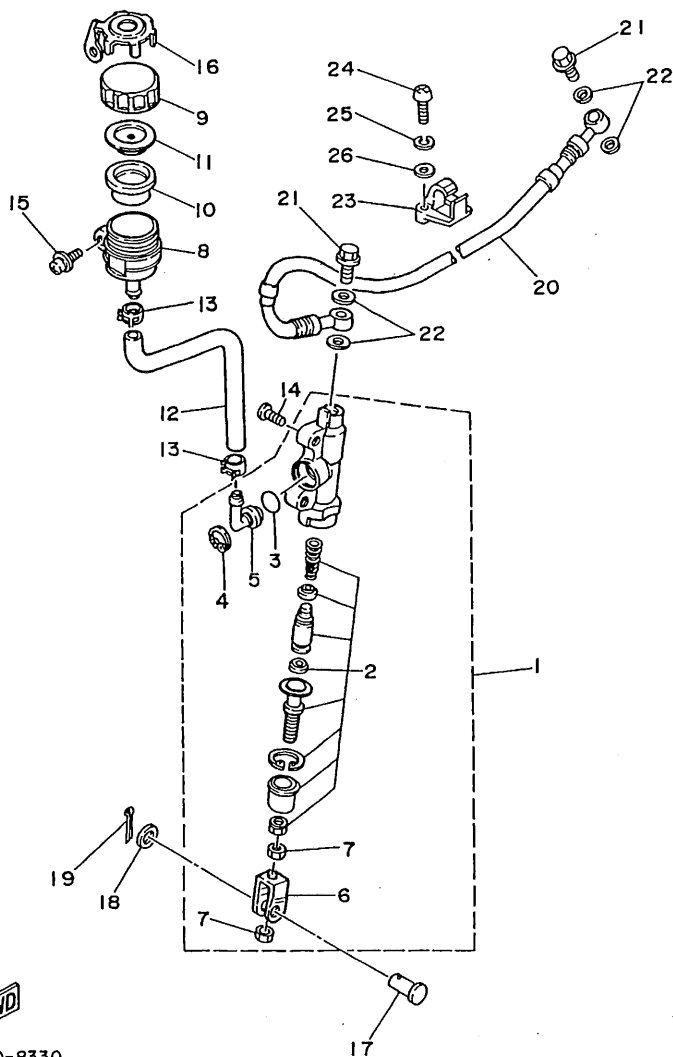

REF. NO.	PART NO.	DESCRIPTION	Q'TY	REMARKS
1	3BN-2583V-00	RR. MASTER CYLINDER ASSY.	1	
2	3BN-W0042-50	.CYLINDER KIT, master	1	
3	93210-15620	.O-RING	1	
4	2VN-25866-00	.CIRCLIP	1	
5	2VN-2582A-50	.JOINT	1	
6	2YK-27222-00	.JOINT	1	
7	95303-08600	.NUT	2	
8	2VN-25894-00	TANK, reservoir	1	
9	2VN-25852-50	CAP, reservoir	1	
10	2VN-25854-00	DIAPHRAGM, reservoir	1	
11	2VN-25855-00	BUSH, diaphragm	1	
12	3BN-25895-00	HOSE, reservoir	1	
13	90467-11044	CLIP	2	
14	92011-06016	SCREW	2	
15	90159-06056	SCREW, with washer	1	
16	3ET-25888-00	COVER, reservoir tank	1	
17	90240-08124	PIN, clevis	1	
18	90201-08083	WASHER, plate	1	
19	91401-16012	PIN, cotter	1	
20	3BN-25873-01	HOSE, brake 2	1	
21	90401-10096	BOLT, union	2	
22	90201-10118	WASHER, plate	4	
23	3BN-25876-00	HOLDER, brake hose 2	2	
24	98501-05020	SCREW, pan head	4	
25	92901-05100	WASHER, spring	4	
26	92901-05600	WASHER, plate	4	



3ET010-8330

E3



FIG. 35 COWLING 1

REF. NO.	PART NO.	DESCRIPTION	Q'TY	REMARKS
1	3BN-Y2835-60	BODY, cowling	1	UR PURPLISH WHITE SOLID 1
	3BN-Y2835-70	BODY, cowling	1	UR PASTEL MINERAL BLUE
	2KF-Y2835-40	BODY, cowling	1	UR YAMAHA BLACK
2	3RM-28391-00	.GRAPHIC 1	1	UR FOR PWS1
	3RM-28391-10	.GRAPHIC 1	1	UR FOR YB
	3RM-28391-20	.GRAPHIC 1	1	UR FOR PMIB
3	98903-06010	SCREW, bind	2	

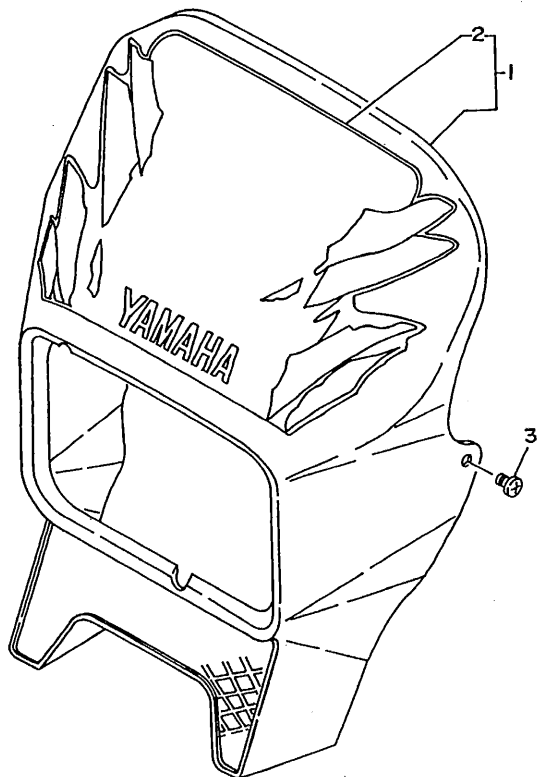

3RM5300-3350

**E4**

FIG. 36 GENERATOR

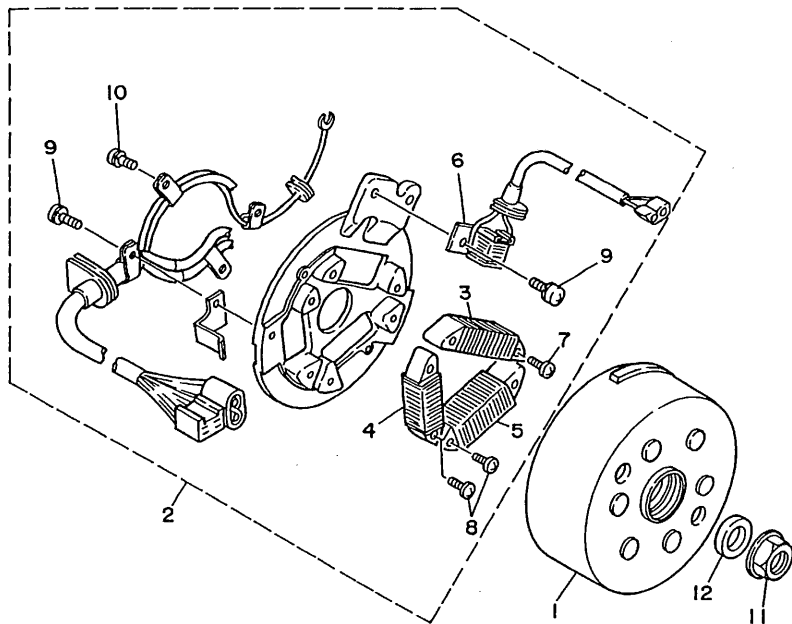

REF. NO.	PART NO.	DESCRIPTION	Q'TY	REMARKS
1	3NC-85550-00	ROTOR ASSY	1	
2	3BN-85560-00	BASE ASSY	1	
3	3BN-85520-00	.COIL, charge	1	
4	3BN-81313-00	.COIL, lighting 1	1	
5	3BN-81314-00	.COIL, lighting 2	1	
6	34X-85595-M0	.COIL, pulser	1	
7	98511-04012	.SCREW, pan head	2	
8	98511-04030	.SCREW, pan head	4	
9	98580-04008	.SCREW, pan head	2	
10	97601-04106	.SCREW, pan head with washer	3	
11	90179-12421	NUT	1	
12	90201-123L6	WASHER, plate	1	



3BN300-8360

E5

FIG. 37 FLASHER LIGHT

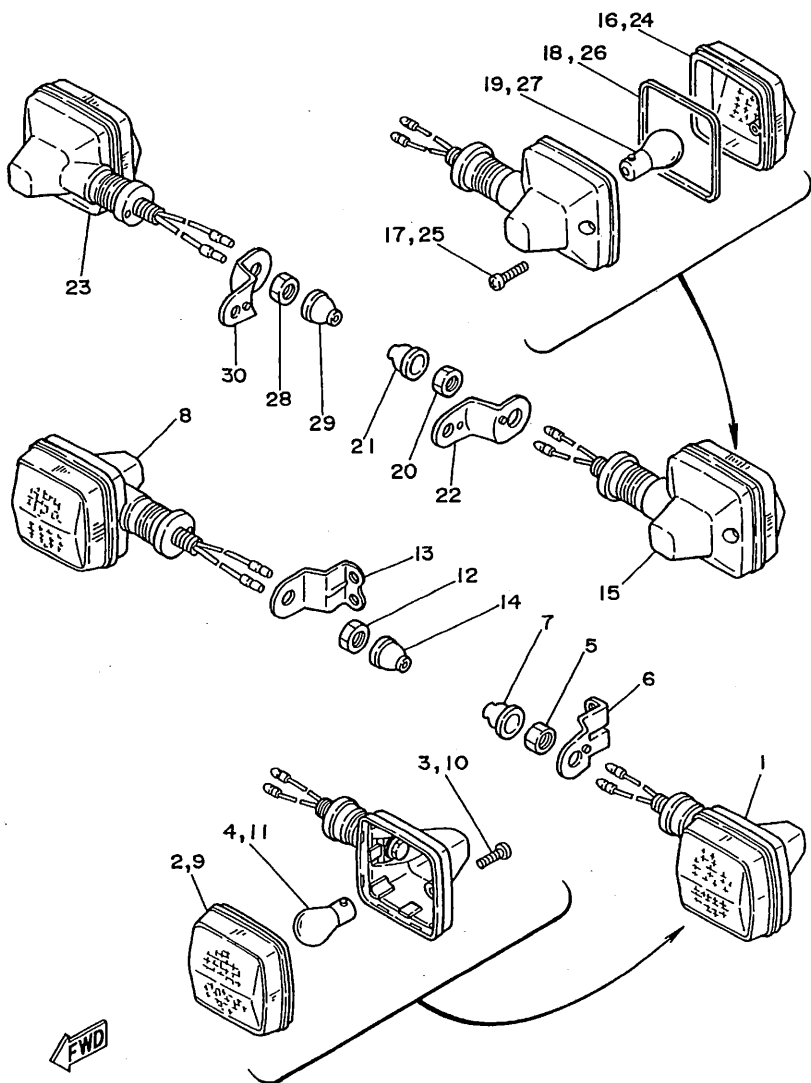

3BN300-8370

REF. NO.	PART NO.	DESCRIPTION	Q'TY	REMARKS
1	3BN-83310-00	FRONT FLASHER LIGHT ASSY 1	1	
2	47J-83312-00	.LENS, flasher	1	
3	97706-40620	.SCREW, tapping	1	
4	306-83311-40	.BULB, flasher (12V-21W)	1	
5	95301-12700	NUT	1	
6	3BN-83318-00	STAY, flasher 1	1	
7	10V-83365-00	CAP	1	
8	3BN-83320-00	FRONT FLASHER LIGHT ASSY 2	1	
9	47J-83322-00	.LENS, flasher 2	1	
10	97706-40620	.SCREW, tapping	1	
11	306-83311-40	.BULB, flasher (12V-21W)	1	
12	95301-12700	NUT	1	
13	3BN-83328-00	STAY, flasher 2	1	
14	10V-83365-00	CAP	1	
15	3BN-83330-00	REAR FLASHER LIGHT ASSY 1	1	
16	2KF-83332-00	.LENS, flasher	1	
17	97706-40620	.SCREW, tapping	1	
18	47J-83313-00	.GASKET, flasher lens	1	
19	306-83311-40	.BULB, flasher (12V-21W)	1	
20	95301-12700	NUT	1	
21	10V-83365-00	CAP	1	
22	15A-83368-00	STAY, flasher 1	1	
23	3BN-83340-00	REAR FLASHER LIGHT ASSY 2	1	
24	2KF-83342-00	.LENS, flasher 2	1	
25	97706-40620	.SCREW, tapping	1	
26	47J-83313-00	.GASKET, flasher lens	1	
27	306-83311-40	.BULB, flasher (12V-21W)	1	
28	95301-12700	NUT	1	

E6

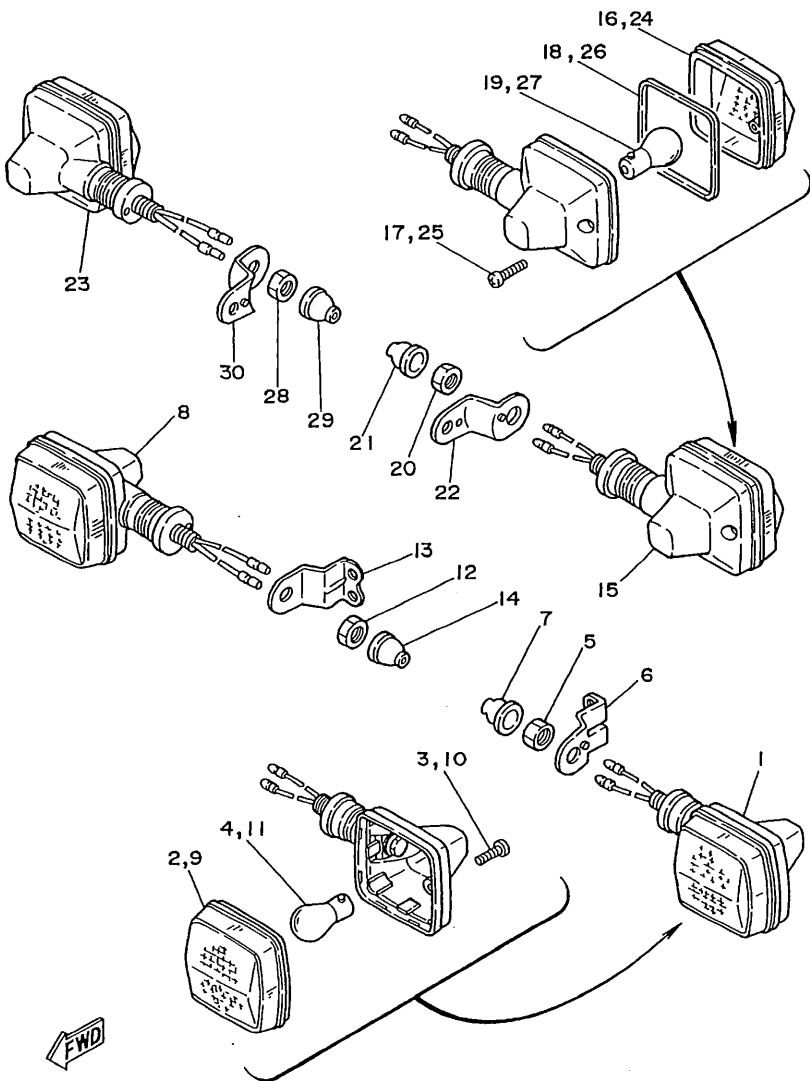

FIG. 37 FLASHER LIGHT

REF. NO.	PART NO.	DESCRIPTION	Q'TY	REMARKS
29	10V-83365-00	CAP	1	
30	15A-83369-00	STAY, flasher 2	1	

3BN300-8370

E7

FIG. 38 METER

REF. NO.	PART NO.	DESCRIPTION	Q'TY	REMARKS
1	43F-83570-G1	SPEEDOMETER ASSY	1	
2	5Y1-83536-00	.SOCKET, meter	1	
3	4G1-84744-00	.BULB (12V-3.4W)	1	
4	3MB-83540-00	TACHOMETER ASSY	1	
5	17F-83520-00	.SOCKET CORD ASSY	1	
6	4G1-84744-00	.BULB (12V-3.4W)	5	
7	92990-03100	.WASHER, spring	3	
8	95301-03700	.NUT	3	
9	5Y1-83513-00	DAMPER	1	
10	17F-83541-00	DAMPER	1	
11	17F-83519-00	BRACKET, meter	1	
12	1M1-83526-00	DAMPER 2	4	
13	90201-05033	WASHER, plate	4	
14	90468-10050	CLIP	4	
15	91026-06040	BOLT	2	
16	1LN-83550-01	SPEEDOMETER CABLE ASSY	1	
17	3BN-83560-10	TACHOMETER CABLE ASSY	1	

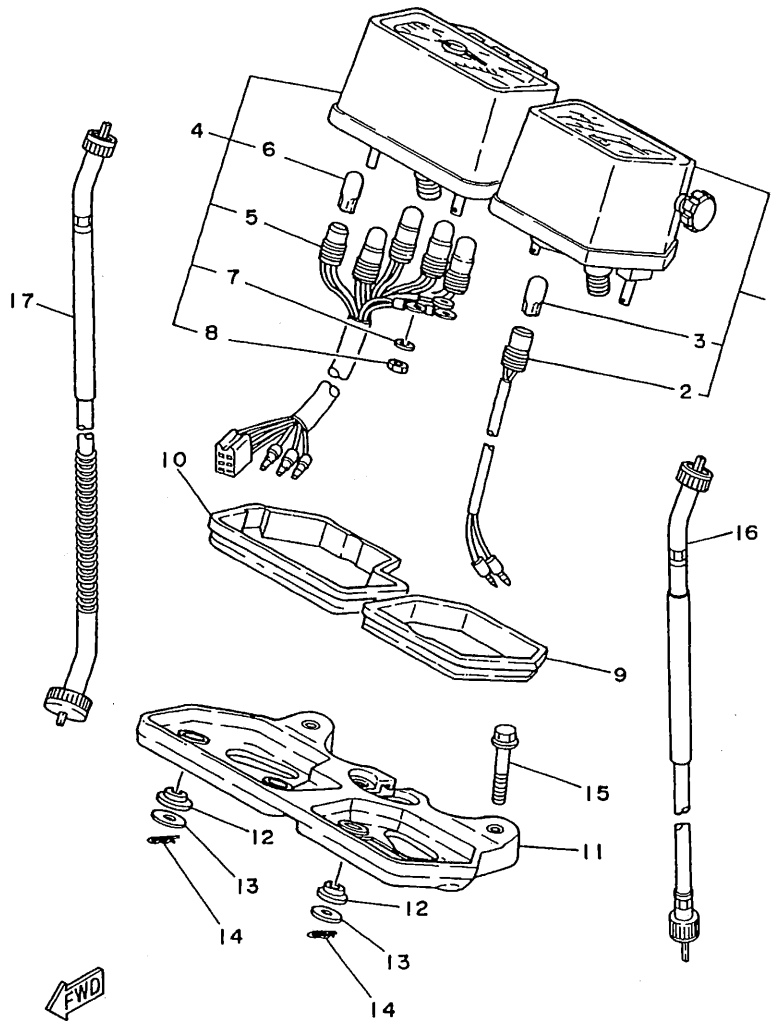

3BN300-8380

E8

FIG. 39 HEADLIGHT

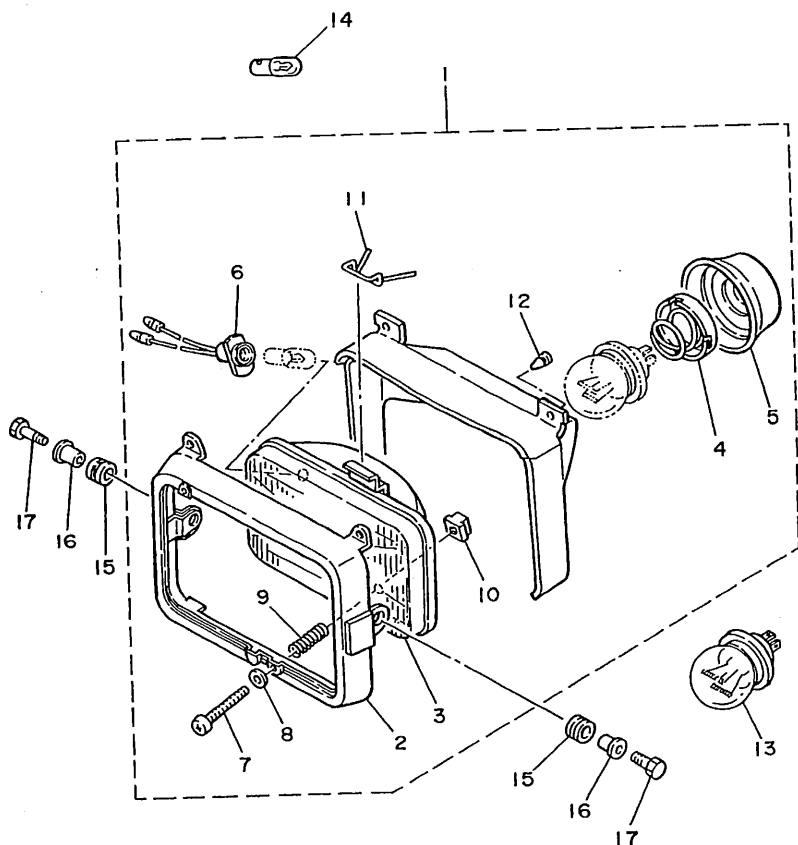

REF. NO.	PART NO.	DESCRIPTION	Q'TY	REMARKS
1	35A-84303-30	HEADLIGHT UNIT ASSY	1	
2	47J-84115-00	.RIM, headlight	1	
3	10W-84321-30	.LENS ASSY	1	
4	341-84393-40	.HOLDER, bulb	1	
5	46X-84396-00	.COVER	1	
6	34L-84346-00	.SOCKET, pilot light	1	
7	43F-84131-00	.SCREW, rim adjuster	2	
8	233-84127-60	.WASHER, special	2	
9	341-84332-60	.SPRING, screw	2	
10	198-84334-60	.NUT, adjusting	2	
11	562-84324-A0	.SPRING, reflector	1	
12	10V-84198-00	.CLIP, cover fitting	4	
13	*	BULB, head light (12V45/40W)	1	LM
14	*	BULB (12V-4W)	1	LM
15	90480-14023	GROMMET	2	
16	90387-06388	COLLAR	2	
17	97001-06020	BOLT	2	



38N300-8390

FIG. 40 TAILLIGHT

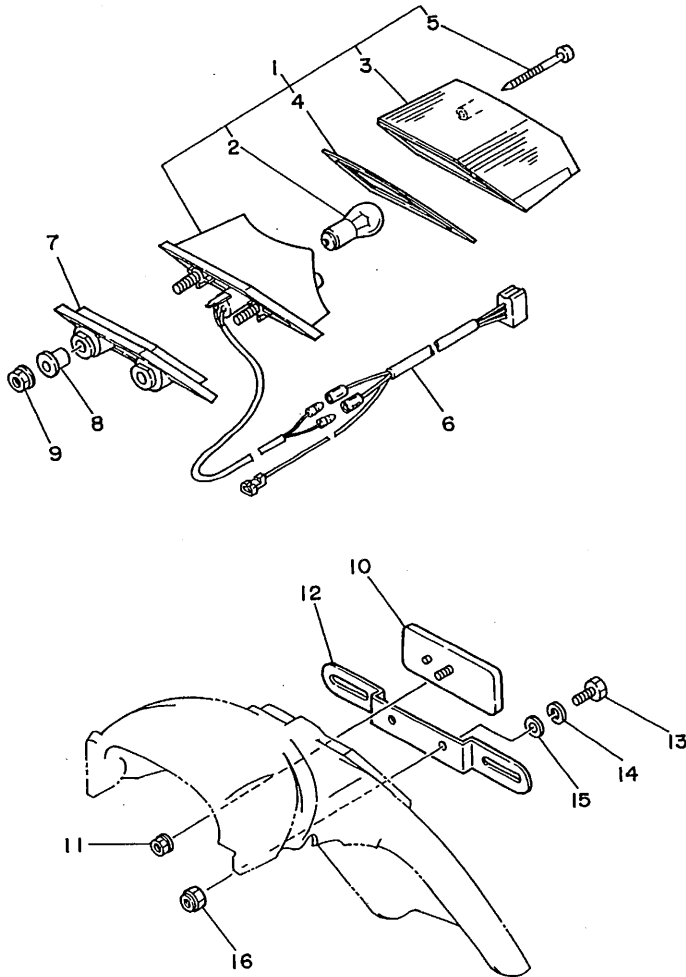

REF. NO.	PART NO.	DESCRIPTION	Q'TY	REMARKS
1	34Y-84710-E1	TAILLIGHT UNIT ASSY	1	
2	31L-84714-00	.BULB, taillight (12V-21/5W)	1	
3	34Y-84721-E0	.LENS, taillight	1	
4	34Y-84723-E0	.GASKET, tail lens	1	
5	97706-40530	.SCREW, tapping	2	
6	10V-84517-00	CORD, taillight	1	
7	34X-84527-00	DAMPER	1	
8	90387-07391	COLLAR	2	
9	95701-06500	NUT, flange	2	
10	3Y6-85130-02	REAR REFLECTOR ASSY	1	
11	95701-05500	NUT, flange	1	
12	36A-84551-00	BRACKET, licence	1	
13	97016-06016	BOLT	2	
14	92906-06100	WASHER, spring	2	
15	90201-065F3	WASHER, plate	2	
16	95601-06100	NUT, u	2	



3BN300-8400

E10

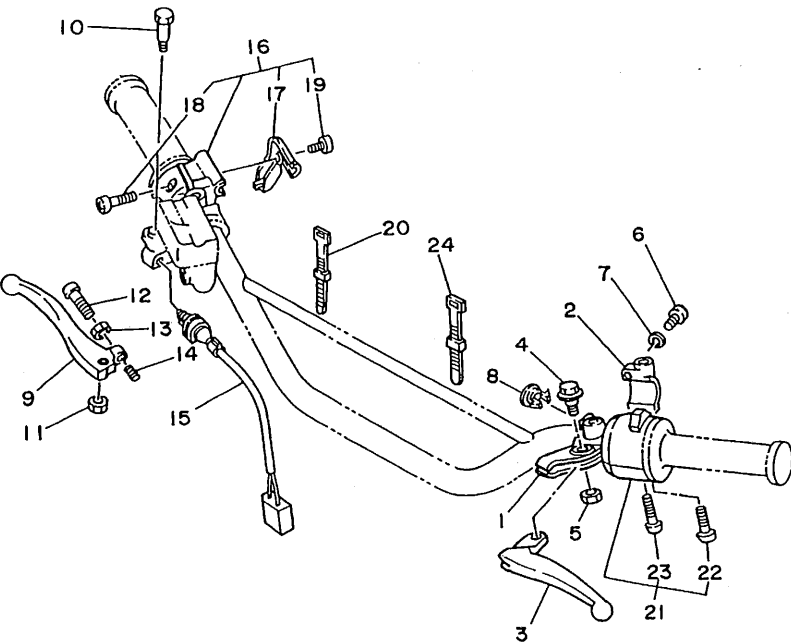

FIG. 41 HANDLE SWITCH. LEVER

REF. NO.	PART NO.	DESCRIPTION	Q'TY	REMARKS
1	1LN-82911-00	HOLDER, lever 1	1	
2	33G-82913-00	HOLDER, lever lower 1	1	
3	3RN-83912-00	LEVER 1	1	
4	90109-06799	BOLT	1	
5	95616-06100	NUT, u	1	
6	98506-05020	SCREW, pan head	2	
7	92906-05100	WASHER, spring	2	
8	503-83956-00	CAP 1	1	
9	3RN-83922-00	LEVER 2	1	
10	90109-062A8	BOLT	1	
11	95616-06100	NUT, u	1	
12	90149-06131	SCREW	1	
13	90170-06355	NUT	1	
14	90501-10312	SPRING, compression	1	
15	34X-83980-01	FRONT STOP SWITCH ASSY	1	
16	47J-83976-01	SWITCH, handle 1	1	
17	33G-83956-01	.CAP 1	1	
18	98506-05020	.SCREW, pan head	2	
19	98906-04008	.SCREW, bind	1	
20	437-83936-01	BAND, switch cord	2	
21	30X-83972-00	SWITCH, handle 4	1	
22	98506-05030	.SCREW, pan head	1	
23	98506-05035	.SCREW, pan head	1	
24	437-83936-01	BAND, switch cord	2	



4DJ1361-1410



FIG. 42 ELECTRICAL 1

REF. NO.	PART NO.	DESCRIPTION	Q'TY	REMARKS
1	2JN-82310-M0	IGNITION COIL ASSY	1	
2	90153-06059	SCREW, hexagon	2	
3	2TV-82370-00	PLUG CAP ASSY	1	WITH NOISE SUPPRESSOR
4	30W-82110-79	BATTERY ASSY (FB3L-B)	1	
5	90445-084E3	HOSE	1	
6	2RH-82115-00	WIRE, plus lead	1	
7	558-82116-00	WIRE, minus lead	1	
8	55K-82150-01	FUSE HOLDER ASSY	1	
9	116-82151-00	.FUSE (10A)	1	
10	3BN-82131-00	BAND, battery	1	
11	3LY-82501-00	MAIN SWITCH STEERING LOCK	1	
12	90149-06228	SCREW	2	
13	3BN-82530-02	STOP SWITCH ASSY	1	
14	90462-12176	CLAMP	1	
15	98506-05008	SCREW, pan head	1	
16	2H7-82540-00	NEUTRAL SWITCH ASSY	1	
17	341-82543-00	.GASKET	1	
18	3RM-82590-00	WIRE HARNESS ASSY	1	
19	25G-83936-01	BAND, switch cord	1	
20	437-83936-01	BAND, switch cord	2	
21	12R-82591-00	BAND	2	
22	3TB-83936-00	BAND, switch cord	4	
23	437-83936-11	BAND, switch cord	1	
24	437-83936-01	BAND, switch cord	2	
25	3BN-85720-00	OIL LEVEL GAUGE ASSY	1	

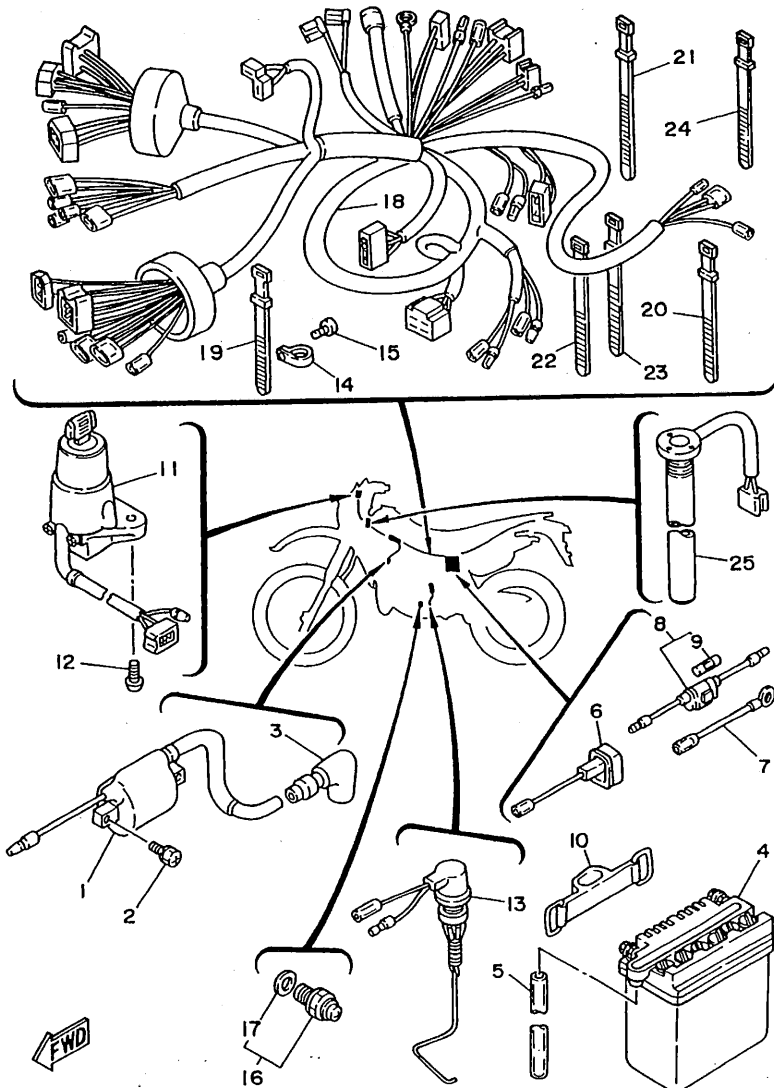

3RM3300-1420

E12

FIG. 43 ELECTRICAL 2

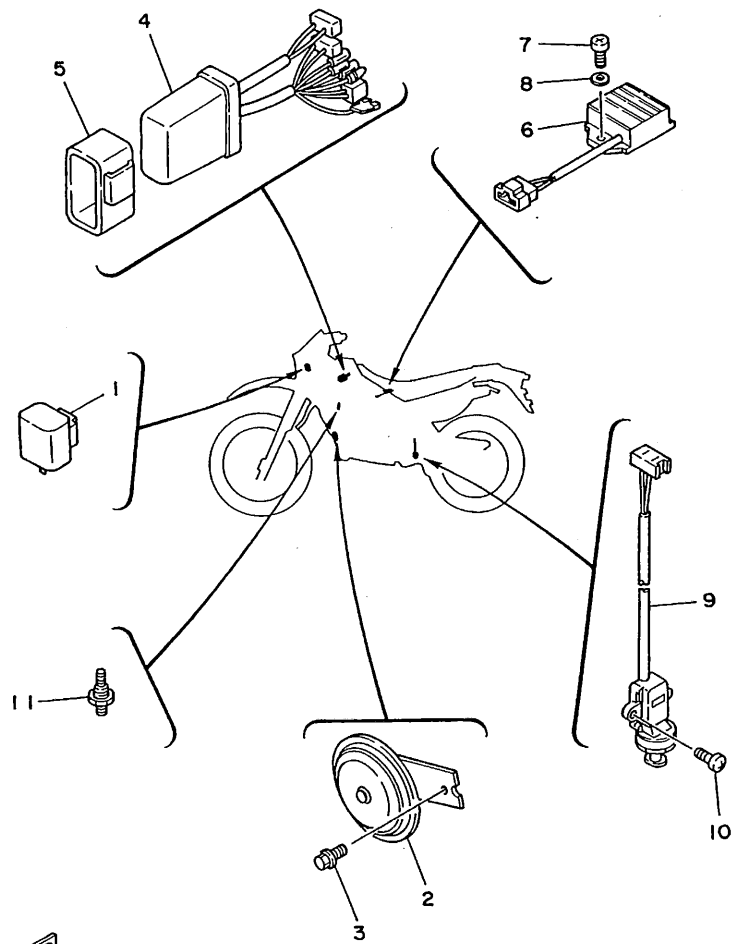

REF. NO.	PART NO.	DESCRIPTION	Q'TY	REMARKS
1	34L-83350-20	FLASHER RELAY ASSY	1	
2	3BN-83371-00	HORN	1	
3	91026-06012	BOLT	1	
4	3NC-85540-00	C.D.I. UNIT ASSY	1	
5	3MB-85546-00	BAND	1	
6	3BN-81960-01	RECTIFIER & REGULATOR ASSY	1	
7	98501-06012	SCREW, pan head	2	
8	92990-06600	WASHER, plate	2	
9	3LD-82566-60	SWITCH, side stand	1	
10	98506-05014	SCREW, pan head	2	
11	11H-83591-00	THERMO UNIT	1	

FWD  
3RN1310-9430

E13

NUMERICAL INDEX

PART NO.	GRID NO.	PART NO.	GRID NO.	PART NO.	GRID NO.	PART NO.	GRID NO.	PART NO.	GRID NO.	PART NO.	GRID NO.
59X-W0041-00	D-14	3BN-12483-00	B- 6	3BN-14421-00	B- 9	1V1-16324-00	C- 3	3BN-2137X-40	C-12	3RM-21781-20	C-13
3BN-W0042-50	E- 3	2RH-12484-00	B- 6	3BN-14425-00	B-10	1HX-16331-00	C- 3	3BN-2137X-60	C-12	22W-21791-00	C-11
3BN-W0045-01	D-10	3MB-13101-01	B- 8	34X-1443E-00	B-10	37F-16351-00	C- 3	3BN-2141E-00	C- 9	3BN-21791-00	C-11
34X-W0046-02	D-12	3MT-13116-00	B- 8	3ET-14437-00	B-10	1W1-16356-02	C- 3	3BN-21425-00	C- 9		C-12
2NA-W0047-00	D-12	363-13133-01	B- 8	3BN-14451-01	B- 9	3R1-16357-00	C- 3	2K7-2148A-00	C- 9	3BN-21871-00	C-14
34X-W0047-00	D-10	137-13137-00-10	B- 8	3BN-14452-00	B- 9	30X-16358-00	C- 3	28K-21511-11	C-10	10V-21875-00	C-14
2VN-W0057-00	D-12	137-13138-01	B- 8	3MB-14453-00	B- 9	2TV-16371-00	C- 3	3BN-21511-40	C-10	3BN-21877-00	C-14
34X-W0057-00	D-10	3BN-13174-00	B- 8	3BN-14458-00	B- 9	3BN-16380-00	C- 3	3XJ-21511-01	C-10	3BN-22110-01-35	C-15
2KF-Y2835-40	E- 4	55K-13175-01	B- 8	3BN-14459-00	B- 9	3BN-16383-00	C- 3	3BN-21611-10	C-10	3R4-22141-00	C-15
3BN-Y2835-60	E- 4	1E7-13176-00	B- 8	3BN-14467-00	B- 9	3BN-17121-00	C- 4	3BN-21611-40	C-10	1LN-22151-00	D- 2
3BN-Y2835-70	E- 4	10V-13178-01	B- 8	3MB-14610-01	B-13	3BN-17131-01	C- 4	3BN-21611-60	C-10	34X-22153-00	D- 2
3BN-11111-02	B- 2	3BN-13416-00	C-14	3PA-14613-10	B-13	3BN-17151-01	C- 4	3BN-21638-00	C-14	3BN-2217A-00	C-15
3MB-11181-00	B- 2	353-13552-01	B- 8	2YK-14714-00	B-13	3MB-17161-00	C- 4	3BN-21639-00	C-10	3BN-2217F-00	C-15
3MB-1131A-00	B- 2	3ET-13565-00	B- 9	3BN-14718-00	B-13	2TV-17211-01	C- 4	3BN-21642-00	C-10	30X-22178-00	C- 9
3BN-1131E-00	B- 2	1AE-13575-00	B- 9	3MB-14753-00	B-13	3BN-17221-00	C- 4	3BN-21685-00	C-10	10V-22184-00	C- 9
3MD-1131F-00	B- 2	3ET-13581-00	B- 9	3BN-14758-00	B-13	3BN-17231-01	C- 4	3BN-21711-10	C-11	30X-2219X-00	C-15
3BN-1131N-00	B- 2	3MB-13610-00	B- 9	565-14771-00	B-13	3XP-17241-00	C- 4	3BN-21711-40	C-11	3RM-22210-10-PO	D- 3
3DB-1131U-10	B- 2	2TV-13613-00	B- 9	3ME-1490J-00	B-11	3BN-17251-02	C- 4	3BN-21711-60	C-11	1YW-22216-00	D- 3
3MB-11311-00	B- 2	3MB-13613-00	B- 9	25G-14937-00	B-11	3XP-17261-00	C- 4	3BN-2172A-00	C-11	3TB-22311-00	D- 2
3BN-11351-10	B- 2	3BN-13616-00	B- 9	1KT-14994-00	B-11	3MB-17411-01	C- 4	1LX-2172F-01	C-12	3BN-23102-01	D- 5
3RM-11400-00	B- 3	3MB-13616-00	B- 9	3BN-15111-03	B-14	3BN-17421-00	C- 4	3BN-2172K-00	C-11	3BN-23103-01	D- 5
3RM-11412-00	B- 3	1KT-13621-01	B- 9	3BN-15121-02	B-14	3RM-17460-00	C- 4	3BN-2172L-00	C-12	3BN-23110-00	D- 5
3MB-11422-00	B- 3	3ET-1410A-00	B-11	37F-15128-00	B-14	55K-17471-00	C- 5	3BN-21721-11	C-11		D- 5
2RH-11454-00	B- 3	3MB-14101-00	B-11	3BN-15199-01	B-14	4LO-17811-00	C- 6	3BN-21721-40-98	C-11	3EN-23111-50	D- 5
55K-11530-00	B- 3	3ET-14103-00	B-11	328-15316-00	B-14	4LO-17818-00	C- 6	3BN-21721-60-98	C-11		D- 6
10V-11536-01	B- 3	3ME-14104-00	B-12	3BN-15317-00	B-14	17F-17831-00	C- 6	3RM-2173E-00	C-12	3BN-23118-01	D- 5
3MB-11610-01	B- 3	2MA-14107-28	B-11	3Y1-15361-00	B-15	17F-17841-00	C- 6	3RM-2173E-10	C-12		D- 6
3MB-11610-11	B- 3	2TV-14112-25	B-11	1RG-15363-00	B-15	17F-17861-00	C- 6	3RM-2173E-20	C-12	4H7-23119-00	D- 5
3MB-11610-21	B- 3	2RJ-14118-00	B-12	3YJ-15371-00	B-14	10W-18101-03	C- 8	3RM-2173F-00	C-12		D- 6
3MB-11631-01-95	B- 3	1KT-14131-00	B-11	3ET-15379-00	B-15	3BN-18110-00	C- 8	3RM-2173F-10	C-12	3BN-23125-00	D- 5
3MB-11633-00	B- 3	8A7-14139-00	B-11	3BN-15411-10	B-15	1W6-18113-00	C- 8	3RM-2173F-20	C-12		D- 5
3MB-11635-01	B- 3	1KT-14141-52	B-11	3BN-15416-10	B-15	3BN-18140-00	C- 7	3RM-2173L-00	C-12	3BN-23126-00	D- 5
3MB-11636-01	B- 3	193-14142-22	B-11	3BN-15421-10	B-15	55K-18511-01	C- 7	3RM-2173L-10	C-12	2KF-23127-01	D- 6
2RH-11651-00	B- 3	137-14143-42-A0	B-11	3BN-15441-00	B- 2	2RH-18512-00	C- 7	3RM-2173L-20	C-12	122-23129-00	D- 5
37F-11681-00	B- 3	1KT-14147-00	B-11	3BN-15451-10	B-15	55K-18513-00	C- 7	3BN-2174A-00	C-13		D- 6
34X-12411-00	B- 6	137-14153-00	B-11	3BN-15456-10	B-15	55K-18531-00	C- 7	3RM-2174L-00	C-12	3BN-23136-00	D- 5
3BN-12414-10	B- 6	3ET-14153-00	B-11	2RH-15492-00	B-14	3BN-18535-00	C- 7	3RM-2174L-10	C-12	3BN-23141-01	D- 5
3BN-12422-11	B- 5	127-14161-00	B-11	156-15618-01	C- 2	3XP-18540-00	C- 7	3RM-2174L-20	C-13		D- 6
3BN-12428-11	B- 5	3X3-14169-00	B-11	3BN-15620-00	C- 2	3RN-21110-00-UJ	C- 9	3BN-2174T-00	C-13	43F-23142-10	D- 5
1KT-12437-00	B- 7	2MA-14185-00	B-11	10V-15621-01	C- 2	3RN-21110-00-33	C- 9	3BN-21747-00	C-11		D- 6
36F-12450-00	B- 5	537-14186-00	B-11	10V-15641-00	C- 2	3BN-21190-00-UJ	C- 9	3BN-2175H-00	C-12	43F-23144-10	D- 5
2RH-12459-00	B- 5	12R-14191-00	B-11	10V-15651-00	C- 2	3BN-21190-00-33	C- 9	3BN-21751-00	C-14		D- 5
3BN-12460-00	B- 6	493-14196-00	B-12	10V-15660-00	C- 2	55E-21308-00	C- 9	3BN-2176E-00	C-14	3BN-23145-00	D- 5
1KT-12462-00	B- 6	3MB-14197-00	B-11	10V-15666-00	C- 2	3ET-21339-00	C-14	4U5-2176E-00	C-11		D- 5
3BN-12469-00	B- 6	3X3-14197-00	B-11	2A6-16111-00	C- 3	3BN-2137W-10	C-11	3BN-2177A-00	C-14	3BN-23146-00	D- 5
3BN-12481-00	B- 6	1KT-14198-00	B-11	3BN-16150-01	C- 3	3BN-2137W-40	C-11	3BN-21770-00	C-14		D- 6
2TV-12482-01	B- 6	3BN-14411-00	B- 9	2TV-16154-00	C- 3	3BN-2137W-60	C-11	3RM-21781-00	C-13	36Y-23146-10	D- 5
3BN-12482-00	B- 6	3BN-14412-00	B- 9	21V-16321-00	C- 3	3BN-2137X-10	C-12	3RM-21781-10	C-13		D- 5

NUMERICAL INDEX

PART NO.	GRID NO.	PART NO.	GRID NO.	PART NO.	GRID NO.	PART NO.	GRID NO.	PART NO.	GRID NO.	PART NO.	GRID NO.
26H-23156-00	D-5	3BN-24731-50	D-8	2VN-25894-00	E-3	55K-82150-01	E-12	3RN-83912-00	E-11	90109-06757	D-10
	D-5	3BN-24731-70	D-8	3BN-25895-00	E-3	116-82151-00	E-12	3RN-83922-00	E-11	90109-06799	E-11
4V4-23158-LO	D-5	3BN-24830-00	D-8	2KF-25919-00	D-12	2JN-82310-00	E-12	25G-83936-01	E-12	90109-085E3	B-13
	D-6	34Y-25104-00	D-9	34X-25919-00	D-10	2TV-82370-00	E-12	3TB-83936-00	E-12	90109-08618	D-11
4V2-23167-LO	D-6	34X-25111-02-35	D-9	2GV-25926-00	D-12	3LY-82501-00	E-12	437-83936-01	E-11	90109-08789	D-15
3BN-23170-00	D-5	322-25118-00	D-9	34X-25926-00	D-10	3BN-82530-02	E-12		E-11	90109-100E2	D-3
	D-6	55U-25181-01	D-9	34X-25937-00	D-10	2H7-82540-00	E-12		E-12	90109-10474	D-15
4V4-23173-LO	D-5	1W2-25190-01	D-9		D-12	341-82543-00	E-12		E-12	90109-10704	D-3
	D-6	3BN-25304-00	D-11	5R2-25937-00	D-10	3LD-82566-60	E-13	437-83936-11	E-12	90116-08042	B-13
3BN-23174-00	D-4	3BN-25311-01-35	D-11		D-12	3RM-82590-00	E-12	33G-83956-01	E-11	90116-08318	B-2
4V4-23181-LO	D-5	4V4-25367-00	D-11	2JX-26111-00	D-13	12R-82591-00	E-12	503-83956-00	E-11	90116-08388	B-2
	D-6		D-11	2KF-26141-00	D-13	1LN-82911-00	E-11	30X-83972-00	E-11	90116-08394	B-2
43F-23188-10	D-5	3BN-25381-00	D-11	3BN-26141-20	D-13	33G-82913-00	E-11	47J-83976-01	E-11	90119-05001	C-3
	D-6	3BN-25388-00	D-11	2YK-26142-10	D-13	3BN-83310-00	E-6	34X-83980-01	E-11	90119-06042	C-10
3BJ-23191-01	D-6	3BN-25389-00	D-11	3BN-26142-20	D-13	306-83311-40	E-6	47J-84115-00	E-9	90119-06043	D-8
3BN-23191-30	D-6	3MB-25457-20	D-11	33G-26241-00	D-13		E-6	233-84127-60	E-9	90119-06056	B-10
3TB-23191-11	D-6	3BN-25715-40	D-10	33G-26242-00	D-13		E-6	43F-84131-00	E-9		C-14
43M-23192-LO	D-6	55U-25715-00	D-10	434-26243-00	D-13		E-6	10V-84198-00	E-9		C-14
3BN-23317-00	D-4	3BN-25716-50	D-10	1M1-26249-01	D-13	47J-83312-00	E-6	35A-84303-30	E-9	90119-06061	B-2
3R4-23317-00	D-6	55U-25716-00	D-10	55V-26280-00	D-13	47J-83313-00	E-6	10W-84321-30	E-9	90119-06097	C-10
26A-23318-00	D-4	3ET-25719-00	D-10	55V-26290-00	D-13		E-6	562-84324-A0	E-9	90119-06117	D-2
3BN-23340-00	D-6	3BN-2580T-10	D-10	3ET-26301-00	D-13	3BN-83318-00	E-6	341-84332-60	E-9		D-2
4V5-23389-00	D-6	3BN-2580W-10	D-12	3BN-26335-00	D-13	3BN-83320-00	E-6	198-84334-60	E-9	90119-06118	C-14
22F-23411-01	D-4	2VN-2582A-50	E-3	1E6-26342-00	D-13	47J-83322-00	E-6	34L-84346-00	E-9	90119-06123	B-10
22F-23412-01	D-4	3BN-2582T-00	D-10	3BN-27211-00	D-15	3BN-83328-00	E-6	341-84393-40	E-9	90119-06172	C-9
10V-23416-01	D-4	3BN-2582W-00	D-12	2YK-27222-00	E-3	3BN-83330-00	E-6	46X-84396-00	E-9	90119-06194	C-10
3BN-23435-00-35	D-4	47X-25824-00	D-10	55V-27242-00	D-15	2KF-83332-00	E-6	10V-84517-00	E-10	90123-08046	D-13
1E6-23441-10-35	D-4		D-12	3BN-27311-02	D-15	3BN-83340-00	E-6	34X-84527-00	E-10	90149-06011	D-7
30X-23445-00	D-4	51L-25825-00	D-10	42U-27315-01	D-15	2KF-83342-00	E-6	36A-84551-00	E-10	90149-06131	E-11
134-23484-10	D-4		D-12	2VN-27411-00	D-15	34L-83350-20	E-13	34Y-84710-E1	E-10	90149-06194	C-11
3BN-24110-00-PO	D-7	2KF-25827-00	D-12	2VN-27421-00	D-15	10V-83365-00	E-6	31L-84714-00	E-10		D-10
3BN-24110-00-T7	D-7	2KF-25828-00	D-12	120-27431-00	D-15		E-6	34Y-84721-E0	E-10	90149-06228	E-12
3BN-24110-00-33	D-7	3BN-2583V-00	E-3	3BN-27432-00-33	D-15		E-6	34Y-84723-E0	E-10	90149-06270	D-12
3BN-2414H-00	D-7	34X-25845-00	D-10	120-27433-00	D-15		E-7	4G1-84744-00	E-8	90149-08269	D-15
3BN-2414J-00	D-7		D-12	3BN-27442-00-33	E-2	15A-83368-00	E-6		E-8	90151-06025	C-9
26H-24181-00	D-7	2KF-25850-00	D-14	2KF-27491-00	D-12	15A-83369-00	E-7	3Y6-85130-02	E-10	90153-06059	E-12
3BN-24182-00	D-7	2KF-25852-01	D-14	3BN-28100-00	C-9	3BN-83371-00	E-13	3BN-85520-00	E-5	90154-05011	B-9
5X2-24184-00	D-7	2VN-25852-50	E-3	10V-28135-00	C-9	5Y1-83513-00	E-8	3NC-85540-01	E-13	90157-06115	B-15
34X-24186-01	D-7	2VN-25854-00	E-3	3RM-28391-00	E-4	17F-83519-00	E-8	3MB-85546-00	E-13	90159-05083	C-12
3ET-24311-00	D-7	55U-25854-00	D-14	3RM-28391-10	E-4	17F-83520-00	E-8	3NC-85550-00	E-5	90159-05163	C-12
3BN-24500-00	D-7	2VN-25855-00	E-3	3RM-28391-20	E-4	1M1-83526-00	E-8	3BN-85560-00	E-5	90159-05167	C-11
4X8-24512-00	D-7	4L0-25862-00	D-14	3BN-81313-00	E-5	5Y1-83536-00	E-8	34X-85595-M0	E-5		C-12
48Y-24602-00	D-7	2VN-25866-00	E-3	3BN-81314-00	E-5	3MB-83540-00	E-8	3BN-85720-00	E-12	90159-05168	C-11
509-24724-00	D-8	56A-25867-00	D-14	3BN-81960-01	E-13	17F-83541-00	E-8	90105-08391	C-9		C-12
3ET-24730-A0	D-8	3BN-25872-01	D-14	30W-82110-79	E-12	1LN-83550-01	E-8	90105-10052	C-9	90159-06056	E-3
3ET-24730-D0	D-8	3BN-25873-01	E-3	2RH-82115-00	E-12	3BN-83560-10	E-8	90105-10308	D-10	90159-06160	C-11
3ET-24730-E0	D-8	3BN-25876-00	E-3	558-82116-00	E-12	43F-83570-G1	E-8	90109-062A8	E-11		C-12
3BN-24731-80	D-8	3ET-25888-00	E-3	3BN-82131-00	E-12	11H-83591-00	E-13	90109-063F7	C-7	90159-06165	C-11

NUMERICAL INDEX

PART NO.	GRID NO.	PART NO.	GRID NO.	PART NO.	GRID NO.	PART NO.	GRID NO.	PART NO.	GRID NO.	PART NO.	GRID NO.
90159-06165	C-12	90201-123L6	E- 5	90387-07391	E-10	90468-08086	B- 8	91701-06022	D-15	93210-30640	B- 2
90170-06355	E-11	90201-12631	C- 2	90387-08201	C-14	90468-10050	D-15	92011-06016	E- 3	93306-00438	D-11
90170-12370	B- 4	90201-14217	C- 3	90387-10510	B-13		E- 8	92011-06060	D- 2	93306-20201	C- 4
	C- 3	90201-154E8	C- 2	90387-126H8	D- 3	90468-26048	C- 2	92901-05100	B- 8	93306-20209	D- 9
90175-06012	B- 9		C- 4	90387-15600	D- 9	90480-01401	C-11		E- 3	93306-20335	B- 3
90176-08040	B- 2	90201-160F6	C-15	90387-164U7	C-15	90480-09481	B-15	92901-05600	D- 4	93306-20431	C- 4
90176-22050	D- 4	90201-164H4	C-15	90387-164U8	C-15	90480-12325	C-11		D-10	93306-30210	B- 3
90179-08148	D-13	90201-170M2	B-14	90387-202T9	B- 3	90480-13398	C-11		E- 3	93306-30438	C- 4
90179-08270	B-13	90201-180P2	C- 3	90387-202U8	D-11	90480-14023	E- 9	92901-06200	C- 3	93306-30556	B- 3
90179-08491	B- 2	90201-200J7	C- 2	90387-204U9	D-11	90480-15363	B- 6	92901-06600	D- 2	93310-31684	B- 3
90179-12244	C- 3	90201-20266	C- 4	90387-205U0	C- 4	90480-16185	C-11		D- 7	93310-52373	B- 3
90179-12374	C- 2	90201-20279	D-15	90387-225N2	D-14		C-12		D-13	93311-31567	C- 4
90179-12421	E- 5	90201-204M9	D-11	90401-06115	B- 6	90480-18411	B-13		D-13	93315-21429	C- 3
90179-16226	C- 4	90201-22555	C- 4		B- 7	90501-02217	B- 8		D-15	93315-32044	C-15
90179-25033	D- 4	90201-251F6	C-15	90401-10034	D-14	90501-08410	D- 7	92902-04100	B-11	93317-32231	C-15
90185-08089	C- 9	90201-254H8	C-15	90401-10096	E- 3	90501-10312	E-11	92906-05100	B- 7	93332-00008	D- 4
90185-08143	C- 9	90202-05187	B-13	90401-14136	C-15	90501-12081	C- 2		C-12	93410-20038	C- 4
90185-08146	D-11		B-13	90402-10005	C-15	90501-20644	C- 3		E-11	93410-22039	C- 4
90185-10037	D-15	90202-05188	B-13	90405-06044	B- 6	90506-18305	D-15	92906-06100	D-14	93430-08036	B- 8
90185-10060	C- 9	90202-05193	D- 7		B- 6	90506-29276	D-15		E-10	93430-08042	C- 2
90185-10120	D- 3	90208-04029	D- 4	90430-04004	D- 4	90508-14352	D-15	92906-06600	B- 9	93440-15012	C- 2
	D- 3	90208-18046	C- 3	90430-06166	C- 3	90508-18765	C- 3		C- 6	93450-17129	B- 3
90185-14070	C-15	90209-06096	B- 9		B- 6	90508-20583	D-15	92990-03100	B- 9	93503-16010	C- 3
90185-16127	C-15	90209-06223	D- 2		B- 6	90508-26561	C- 7		E- 8		D- 4
90201-044A2	C-14	90209-18135	C- 4	90445-057F9	B- 8	90508-26667	C- 2	92990-06100	C-11	93505-32002	B- 8
90201-05033	E- 8	90209-22257	B- 3	90445-07747	B-11	90508-32553	C- 8		D- 7	93507-32031	C- 2
90201-060A3	B- 2	90215-12271	C- 3	90445-084E3	C- 3	90560-08066	C-10	92990-06600	E-13	93603-22028	B- 5
	B-13	90215-12272	B- 4	90445-09073	B- 4		C-14		B- 8		B- 8
90201-06072	B- 6	90215-20283	C- 4	90446-07349	B-14	90560-15290	D- 9	93101-12060	C- 8	93604-10011	B- 5
90201-065F3	E-10	90240-06009	D-15	90446-07349	B- 6	90560-20340	D-11	93102-20281	D- 9	93700-06004	C-15
90201-08083	E- 3	90240-08124	E- 3	90450-22052	B- 6	91001-06016	C-14	93102-20309	C- 2	93700-06005	C-15
90201-08087	B-15	90240-10101	D-15	90450-28014	B- 9	91001-06020	B- 6	93102-25331	B- 3		D- 2
90201-081A6	D-15	90267-40029	C-14	90462-08174	B- 2	91011-10016	C-15	93102-26042	C- 4	94127-214F2	D- 9
90201-081H4	B-13	90269-04003	D- 4	90462-12176	E-12	91026-06010	C-11	93103-10147	B- 5	94127-216T2	D- 9
90201-08512	B- 5	90280-03045	B- 3	90464-13080	D- 7		C-12	93103-32171	B- 3	94141-186T1	D-11
90201-08624	B- 8	90282-05047	B- 3	90465-14242	D- 4	91026-06012	D- 4	93104-14004	C- 3	94141-186T3	D-11
90201-08649	B- 2	90282-05058	B- 3	90467-08003	C-14		E-13	93106-22019	C-15	94225-21186	D- 9
90201-087H6	C- 6	90338-09130	D- 9		C-14	91026-06040	E- 8	93106-28023	D-11	94227-21123	D- 9
90201-08753	C- 9		D-11		D- 7	91026-08035	D- 4	93108-35004	C-15	94235-18085	D-11
90201-094G1	C- 9	90380-16077	C-15	90467-10008	C-14	91316-05012	B- 2	93109-20029	C-15	94241-18153	D-11
90201-100E9	C- 9	90380-22111	C-15		D- 7	91316-05016	B- 2		C-15	94325-21117	D- 9
	D- 3	90386-20120	C-15	90467-10035	B- 6	91316-06012	D- 4	93210-07100	B- 8	94330-21084	D- 9
	D- 3	90387-062V8	C-10		B- 6	91316-08035	D- 4	93210-12154	B-14	94340-18086	D-11
90201-10118	D-14	90387-06388	E- 9	90467-11044	E- 3	91401-16012	E- 3	93210-12327	B- 6	94345-18081	D-11
	E- 3	90387-06500	C-11	90467-11102	B-10	91401-16015	D-15		C- 6	94416-21392	D- 9
90201-10119	D-15		D-13	90467-20050	B- 9	91401-20015	D-15	93210-15620	E- 3	94418-18466	D-11
90201-106F2	C-15	90387-06681	C-14	90468-02033	B- 8	91401-25020	D-15	93210-19123	B-15	94581-33134	D-11
90201-120E8	C- 3	90387-07390	B- 6		B- 8	91401-30030	D-11	93210-27194	B- 6	94681-33011	D-11

NUMERICAL INDEX

PART NO.	GRID NO.	PART NO.	GRID NO.	PART NO.	GRID NO.	PART NO.	GRID NO.	PART NO.	GRID NO.	PART NO.	GRID NO.
94701-00188	B- 2	97706-40620	E- 6	99009-15400	C- 4						
95026-08012	C- 9		E- 6	99080-07600	B- 5						
95026-08040	D- 4	97706-50520	B- 9	99241-00020	C-10						
95301-03700	E- 8	98501-05016	D-10	99244-00020	C-10						
95301-12700	E- 6	98501-05020	E- 3	99510-10114	B- 2						
	E- 6	98501-06012	B- 6	99510-12016	B-14						
	E- 6		B- 6	99530-10014	B-15						
	E- 6		C- 5								
95301-18900	D-11		E-13								
95303-05600	B- 8	98501-06025	B- 5								
	D- 4	98501-06030	B-15								
	D-10		B-15								
95303-06600	C- 3	98501-06035	D-13								
95303-06700	D-13	98501-06040	B-14								
95303-08600	E- 3		B-15								
95601-06100	E-10	98501-06050	B-14								
95616-06100	E-11	98501-06060	B-14								
	E-11	98501-06065	B- 5								
95701-05500	E-10		B-14								
95701-06500	E-10	98501-06070	B-14								
95701-08500	C-10	98502-06012	B-14								
	D- 6	98503-03008	D- 7								
95801-06010	D-12	98503-04014	B-11								
95801-06050	D- 2	98503-05025	D- 4								
95801-08080	B-15	98506-04018	D- 6								
95811-06012	C- 9	98506-05008	E-12								
	C-10	98506-05010	C-12								
95811-06025	B- 5	98506-05014	E-13								
95811-08045	C- 9	98506-05020	E-11								
95811-08055	D- 6		E-11								
95816-06012	B-13	98506-05030	E-11								
	C- 9	98506-05035	E-11								
95816-06025	B-13	98511-04012	E- 5								
95816-08020	C-10	98511-04030	E- 5								
95816-08050	C- 9	98511-08010	B-14								
97001-06020	E- 9	98516-06020	B- 6								
97001-06025	B- 9	98580-03008	B- 9								
97006-05012	B- 7	98580-04008	B-11								
97006-06010	C- 6		E- 5								
97011-06020	C-11	98580-05014	B- 8								
97016-06016	E-10	98706-04012	D-14								
97016-06020	C- 8	98903-06010	E- 4								
97016-06025	D-14	98906-04006	B- 8								
97313-06016	D- 7	98906-04008	E-11								
97601-04106	E- 5	98906-06008	B-13								
97706-40530	E-10	98906-06010	B-13								
97706-40620	E- 6	99006-10600	C- 8								
	E- 6	99009-10400	C- 7								